



ORBITAL SYSTEM CONTROLLER FPA 3020 AC/DC

/ Orbital welding power source



/ The FPA 3020 Orbital system controller is special designed for FCH and FOH weld heads. Due to its lightweight and compact design it is ideal useable for mobile applications. The integrated system controller controls both the power source and the weld head. This guarantees perfect, 100% reproducible welding quality.

FEATURES

- / Lightweight and compact design - ideal for mobile applications
- / Generator compatible
- / Integrated water cooler with water control
- / Integrated microprocessor-controller
- / Intuitive touch-screen operator panel (colour)
- / Language selection (DE/GB/FR/IT/ES/PB/RU/CZ/TR)
- / Remote control FRC-FPA 3020 with 10 m cable
- / Addressing of welding current, rotation axis, purging gas and external wire feeder
- / Recording of imported heat energy
- / USB interface for data transfer and recording
- / Integrated printer for welding data documentation

FUNCTIONS

- / Save / load up to 200 programs
- / 3 tacking programs (up to 20 tacking points)
- / 10 sectors per programm
- / Start / stop with slope, immediate welding stop
- / Emergency-stop
- / Manual positioning of axes
- / Manual wire inching (forward / reverse)
- / Parameter adjusting during welding (on the fly)
- / Shielding gas and purging gas on / off



/ USB interface



/ Remote control FRC-FPA 3020



/ Carriage PickUp (accessory)

TECHNICAL DATA

Mains voltage	230 V
Operating voltage	10,2 - 18 V
Open-circuit voltage	44 V
Mains fuse	16 A
Cos phi	0,99
Welding current AC / DC (stepless)	5 - 200 A
Duty cycle	200 A (10 min/40°C) 35% d.c. 145 A (10 min/40°C) 60% d.c. 110 A (10 min/40°C) 100% d.c.
Cooling power (on 40°C, 1l/min)	500 W
Coolant capacity	1,8 l (0.47 US gal)
Coolant throughput	max. 3,0 l/ min (0.79 US gal/min)
Protection class	IP 23
Dimensions l/w/h	650 x 290 x 480 mm (25.6 x 11.4 x 18.9 in)
Net weight (without remote control)	38 kg (83.77 lb)

SCOPE OF DELIVERY

/ FPA 3020 Orbital system controller
/ Remote control FRC-FPA 3020 with cable 10 m
/ USB flash drive 8 GB

ACCESSORIES

/ Software FPA-Xplorer Offline
/ USB flash drive 8 GB
/ Print paper
/ Ground cable
/ Pressure regulator
/ Carriage PickUp
/ KD 4000-D11 wire feeder
/ TIG manual welding torch

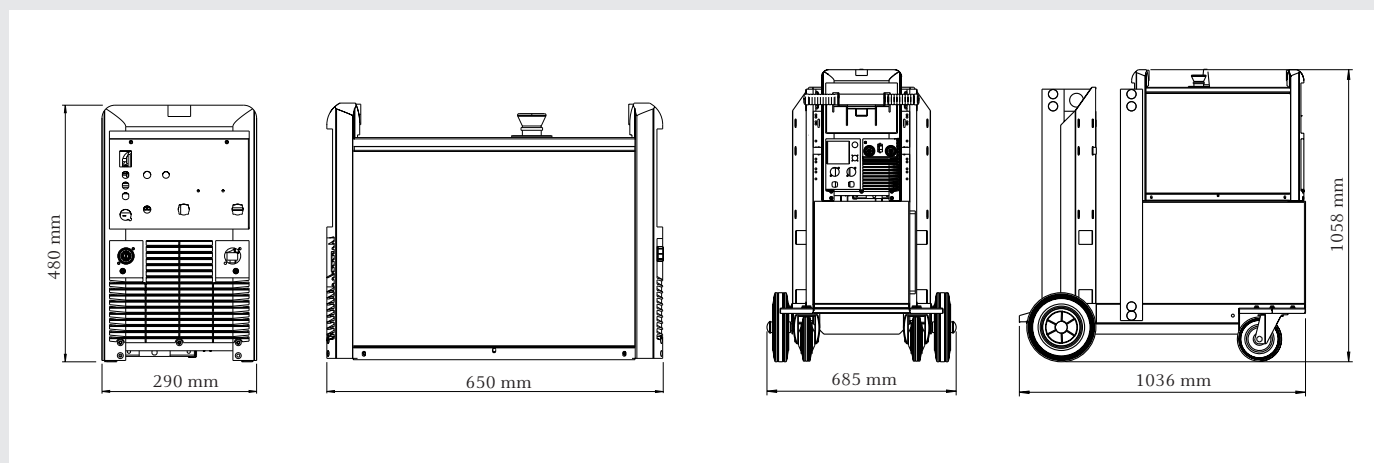

/ Perfect Welding / Solar Energy / Perfect Charging

WE HAVE THREE DIVISIONS AND ONE PASSION: SHIFTING THE LIMITS OF POSSIBILITY.

/ Whether welding technology, photovoltaics or battery charging technology – our goal is clearly defined: to be the innovation leader. With around 3,300 employees worldwide, we shift the limits of what's possible - our record of over 900 granted patents is testimony to this. While others progress step by step, we innovate in leaps and bounds. Just as we've always done. The responsible use of our resources forms the basis of our corporate policy.

Further information about all Fronius products and our global sales partners and representatives can be found at www.fronius.com

v05 May 2015 EN

Fronius Canada Ltd.
2875 Argentia Road, Units 4,5 & 6
Mississauga, ON L5N 8G6
Canada
Telephone +1 905 288-2100
Fax +1 905 288-2101
sales.canada@fronius.com
www.fronius.ca

Fronius USA LLC
6797 Fronius Drive
Portage, IN 46368
USA
Telephone +1 877 FRONIUS
sales.usa@fronius.com
www.fronius-usa.com

Fronius UK Limited
Maidstone Road, Kingston
Milton Keynes, MK10 0BD
United Kingdom
Telephone +44 1908 512 300
Fax +44 1908 512 329
info-uk@fronius.com
www.fronius.co.uk

Fronius International GmbH
Froniusplatz 1
4600 Wels
Austria
Telephone +43 7242 241-0
Fax +43 7242 241-953940
sales@fronius.com
www.fronius.com