

Operator's Manual

HELIX[®] M85 WELD HEAD

For use with machines having Code Numbers:
70315, 12735

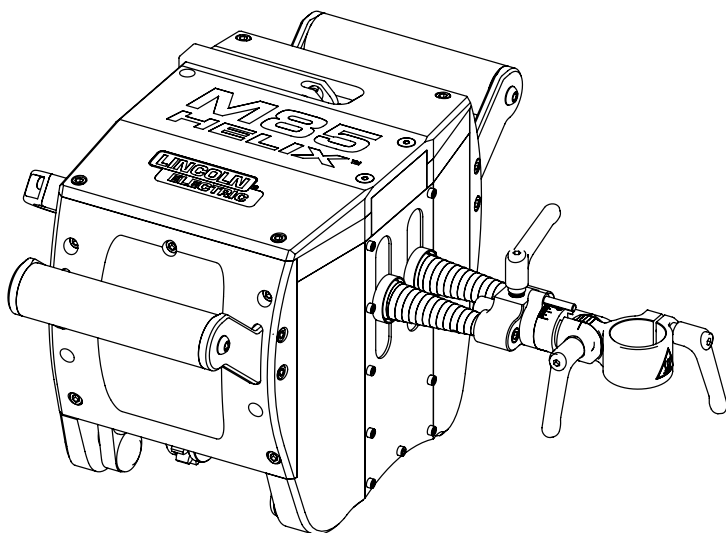

Register your machine:
www.lincolnelectric.com/register
Authorized Service and Distributor Locator:
www.lincolnelectric.com/locator

Save for future reference

Date Purchased

Code: (ex: 12735)

Serial: (ex: U1060512345)

Need Help? Call 1.888.935.3877
to talk to a Service Representative

Hours of Operation:
8:00 AM to 6:00 PM (ET) Mon. thru Fri.

After hours?
Use "Ask the Experts" at lincolnelectric.com
A Lincoln Service Representative will contact you
no later than the following business day.

For Service outside the USA:
Email: globalservice@lincolnelectric.com

THANK YOU FOR SELECTING A QUALITY PRODUCT BY LINCOLN ELECTRIC.

PLEASE EXAMINE CARTON AND EQUIPMENT FOR DAMAGE IMMEDIATELY

When this equipment is shipped, title passes to the purchaser upon receipt by the carrier. Consequently, claims for material damaged in shipment must be made by the purchaser against the transportation company at the time the shipment is received.

SAFETY DEPENDS ON YOU

Lincoln arc welding and cutting equipment is designed and built with safety in mind. However, your overall safety can be increased by proper installation ... and thoughtful operation on your part. **DO NOT INSTALL, OPERATE OR REPAIR THIS EQUIPMENT WITHOUT READING THIS MANUAL AND THE SAFETY PRECAUTIONS CONTAINED THROUGHOUT.** And, most importantly, think before you act and be careful.

WARNING

This statement appears where the information must be followed exactly to avoid serious personal injury or loss of life.

CAUTION

This statement appears where the information must be followed to avoid minor personal injury or damage to this equipment.



KEEP YOUR HEAD OUT OF THE FUMES.

DON'T get too close to the arc. Use corrective lenses if necessary to stay a reasonable distance away from the arc.

READ and obey the Safety Data Sheet (SDS) and the warning label that appears on all containers of welding materials.

USE ENOUGH VENTILATION or exhaust at the arc, or both, to keep the fumes and gases from your breathing zone and the general area.

IN A LARGE ROOM OR OUTDOORS, natural ventilation may be adequate if you keep your head out of the fumes (See below).

USE NATURAL DRAFTS or fans to keep the fumes away from your face.

If you develop unusual symptoms, see your supervisor. Perhaps the welding atmosphere and ventilation system should be checked.

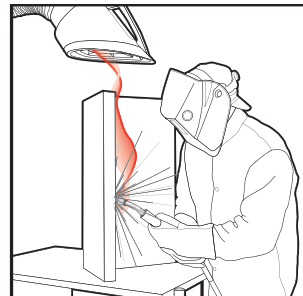

WEAR CORRECT EYE, EAR & BODY PROTECTION

PROTECT your eyes and face with welding helmet properly fitted and with proper grade of filter plate (See ANSI Z49.1).

PROTECT your body from welding spatter and arc flash with protective clothing including woolen clothing, flame-proof apron and gloves, leather leggings, and high boots.

PROTECT others from splatter, flash, and glare with protective screens or barriers.

IN SOME AREAS, protection from noise may be appropriate.

BE SURE protective equipment is in good condition.

Also, wear safety glasses in work area **AT ALL TIMES.**



SPECIAL SITUATIONS

DO NOT WELD OR CUT containers or materials which previously had been in contact with hazardous substances unless they are properly cleaned. This is extremely dangerous.

DO NOT WELD OR CUT painted or plated parts unless special precautions with ventilation have been taken. They can release highly toxic fumes or gases.

Additional precautionary measures

PROTECT compressed gas cylinders from excessive heat, mechanical shocks, and arcs; fasten cylinders so they cannot fall.

BE SURE cylinders are never grounded or part of an electrical circuit.

REMOVE all potential fire hazards from welding area.

ALWAYS HAVE FIRE FIGHTING EQUIPMENT READY FOR IMMEDIATE USE AND KNOW HOW TO USE IT.



SECTION A: WARNINGS



CALIFORNIA PROPOSITION 65 WARNINGS



WARNING: Breathing diesel engine exhaust exposes you to chemicals known to the State of California to cause cancer and birth defects, or other reproductive harm.

- Always start and operate the engine in a well-ventilated area.
- If in an exposed area, vent the exhaust to the outside.
- Do not modify or tamper with the exhaust system.
- Do not idle the engine except as necessary.

For more information go to www.P65warnings.ca.gov/diesel

WARNING: This product, when used for welding or cutting, produces fumes or gases which contain chemicals known to the State of California to cause birth defects and, in some cases, cancer. (California Health & Safety Code § 25249.5 *et seq.*)



WARNING: Cancer and Reproductive Harm
www.P65warnings.ca.gov

ARC WELDING CAN BE HAZARDOUS. PROTECT YOURSELF AND OTHERS FROM POSSIBLE SERIOUS INJURY OR DEATH. KEEP CHILDREN AWAY. PACEMAKER WEARERS SHOULD CONSULT WITH THEIR DOCTOR BEFORE OPERATING.

Read and understand the following safety highlights. For additional safety information, it is strongly recommended that you purchase a copy of "Safety in Welding & Cutting - ANSI Standard Z49.1" from the American Welding Society, P.O. Box 351040, Miami, Florida 33135 or CSA Standard W117.2-1974. A Free copy of "Arc Welding Safety" booklet E205 is available from the Lincoln Electric Company, 22801 St. Clair Avenue, Cleveland, Ohio 44117-1199.

BE SURE THAT ALL INSTALLATION, OPERATION, MAINTENANCE AND REPAIR PROCEDURES ARE PERFORMED ONLY BY QUALIFIED INDIVIDUALS.



FOR ENGINE POWERED EQUIPMENT.

- 1.a. Turn the engine off before troubleshooting and maintenance work unless the maintenance work requires it to be running.
- 1.b. Operate engines in open, well-ventilated areas or vent the engine exhaust fumes outdoors.
- 1.c. Do not add the fuel near an open flame welding arc or when the engine is running. Stop the engine and allow it to cool before refueling to prevent spilled fuel from vaporizing on contact



with hot engine parts and igniting. Do not spill fuel when filling tank. If fuel is spilled, wipe it up and do not start engine until fumes have been eliminated.

- 1.d. Keep all equipment safety guards, covers and devices in position and in good repair. Keep hands, hair, clothing and tools away from V-belts, gears, fans and all other moving parts when starting, operating or repairing equipment.
- 1.e. In some cases it may be necessary to remove safety guards to perform required maintenance. Remove guards only when necessary and replace them when the maintenance requiring their removal is complete. Always use the greatest care when working near moving parts.
- 1.f. Do not put your hands near the engine fan. Do not attempt to override the governor or idler by pushing on the throttle control rods while the engine is running.
- 1.g. To prevent accidentally starting gasoline engines while turning the engine or welding generator during maintenance work, disconnect the spark plug wires, distributor cap or magneto wire as appropriate.
- 1.h. To avoid scalding, do not remove the radiator pressure cap when the engine is hot.



ELECTRIC AND MAGNETIC FIELDS MAY BE DANGEROUS



- 2.a. Electric current flowing through any conductor causes localized Electric and Magnetic Fields (EMF). Welding current creates EMF fields around welding cables and welding machines
- 2.b. EMF fields may interfere with some pacemakers, and welders having a pacemaker should consult their physician before welding.
- 2.c. Exposure to EMF fields in welding may have other health effects which are now not known.
- 2.d. All welders should use the following procedures in order to minimize exposure to EMF fields from the welding circuit:
 - 2.d.1. Route the electrode and work cables together - Secure them with tape when possible.
 - 2.d.2. Never coil the electrode lead around your body.
 - 2.d.3. Do not place your body between the electrode and work cables. If the electrode cable is on your right side, the work cable should also be on your right side.
 - 2.d.4. Connect the work cable to the workpiece as close as possible to the area being welded.
 - 2.d.5. Do not work next to welding power source.

**ELECTRIC SHOCK CAN KILL.**

- 3.a. The electrode and work (or ground) circuits are electrically “hot” when the welder is on. Do not touch these “hot” parts with your bare skin or wet clothing. Wear dry, hole-free gloves to insulate hands.
- 3.b. Insulate yourself from work and ground using dry insulation. Make certain the insulation is large enough to cover your full area of physical contact with work and ground.

In addition to the normal safety precautions, if welding must be performed under electrically hazardous conditions (in damp locations or while wearing wet clothing; on metal structures such as floors, gratings or scaffolds; when in cramped positions such as sitting, kneeling or lying, if there is a high risk of unavoidable or accidental contact with the workpiece or ground) use the following equipment:

- Semiautomatic DC Constant Voltage (Wire) Welder.
 - DC Manual (Stick) Welder.
 - AC Welder with Reduced Voltage Control.
- 3.c. In semiautomatic or automatic wire welding, the electrode, electrode reel, welding head, nozzle or semiautomatic welding gun are also electrically “hot”.
 - 3.d. Always be sure the work cable makes a good electrical connection with the metal being welded. The connection should be as close as possible to the area being welded.
 - 3.e. Ground the work or metal to be welded to a good electrical (earth) ground.
 - 3.f. Maintain the electrode holder, work clamp, welding cable and welding machine in good, safe operating condition. Replace damaged insulation.
 - 3.g. Never dip the electrode in water for cooling.
 - 3.h. Never simultaneously touch electrically “hot” parts of electrode holders connected to two welders because voltage between the two can be the total of the open circuit voltage of both welders.
 - 3.i. When working above floor level, use a safety belt to protect yourself from a fall should you get a shock.
 - 3.j. Also see Items 6.c. and 8.

**ARC RAYS CAN BURN.**

- 4.a. Use a shield with the proper filter and cover plates to protect your eyes from sparks and the rays of the arc when welding or observing open arc welding. Headshield and filter lens should conform to ANSI Z87.1 standards.
- 4.b. Use suitable clothing made from durable flame-resistant material to protect your skin and that of your helpers from the arc rays.
- 4.c. Protect other nearby personnel with suitable, non-flammable screening and/or warn them not to watch the arc nor expose themselves to the arc rays or to hot spatter or metal.

**FUMES AND GASES CAN BE DANGEROUS.**

- 5.a. Welding may produce fumes and gases hazardous to health. Avoid breathing these fumes and gases. When welding, keep your head out of the fume. Use enough ventilation and/or exhaust at the arc to keep fumes and gases away from the breathing zone. **When welding hardfacing (see instructions on container or SDS) or on lead or cadmium plated steel and other metals or coatings which produce highly toxic fumes, keep exposure as low as possible and within applicable OSHA PEL and ACGIH TLV limits using local exhaust or mechanical ventilation unless exposure assessments indicate otherwise. In confined spaces or in some circumstances, outdoors, a respirator may also be required. Additional precautions are also required when welding on galvanized steel.**
- 5.b. The operation of welding fume control equipment is affected by various factors including proper use and positioning of the equipment, maintenance of the equipment and the specific welding procedure and application involved. Worker exposure level should be checked upon installation and periodically thereafter to be certain it is within applicable OSHA PEL and ACGIH TLV limits.
- 5.c. Do not weld in locations near chlorinated hydrocarbon vapors coming from degreasing, cleaning or spraying operations. The heat and rays of the arc can react with solvent vapors to form phosgene, a highly toxic gas, and other irritating products.
- 5.d. Shielding gases used for arc welding can displace air and cause injury or death. Always use enough ventilation, especially in confined areas, to insure breathing air is safe.
- 5.e. Read and understand the manufacturer’s instructions for this equipment and the consumables to be used, including the Safety Data Sheet (SDS) and follow your employer’s safety practices. SDS forms are available from your welding distributor or from the manufacturer.
- 5.f. Also see item 1.b.

**WELDING AND CUTTING SPARKS CAN CAUSE FIRE OR EXPLOSION.**

- 6.a. Remove fire hazards from the welding area. If this is not possible, cover them to prevent the welding sparks from starting a fire. Remember that welding sparks and hot materials from welding can easily go through small cracks and openings to adjacent areas. Avoid welding near hydraulic lines. Have a fire extinguisher readily available.
- 6.b. Where compressed gases are to be used at the job site, special precautions should be used to prevent hazardous situations. Refer to "Safety in Welding and Cutting" (ANSI Standard Z49.1) and the operating information for the equipment being used.
- 6.c. When not welding, make certain no part of the electrode circuit is touching the work or ground. Accidental contact can cause overheating and create a fire hazard.
- 6.d. Do not heat, cut or weld tanks, drums or containers until the proper steps have been taken to insure that such procedures will not cause flammable or toxic vapors from substances inside. They can cause an explosion even though they have been "cleaned". For information, purchase "Recommended Safe Practices for the Preparation for Welding and Cutting of Containers and Piping That Have Held Hazardous Substances", AWS F4.1 from the American Welding Society (see address above).
- 6.e. Vent hollow castings or containers before heating, cutting or welding. They may explode.
- 6.f. Sparks and spatter are thrown from the welding arc. Wear oil free protective garments such as leather gloves, heavy shirt, cuffless trousers, high shoes and a cap over your hair. Wear ear plugs when welding out of position or in confined places. Always wear safety glasses with side shields when in a welding area.
- 6.g. Connect the work cable to the work as close to the welding area as practical. Work cables connected to the building framework or other locations away from the welding area increase the possibility of the welding current passing through lifting chains, crane cables or other alternate circuits. This can create fire hazards or overheat lifting chains or cables until they fail.
- 6.h. Also see item 1.c.
- 6.i. Read and follow NFPA 51B "Standard for Fire Prevention During Welding, Cutting and Other Hot Work", available from NFPA, 1 Batterymarch Park, PO box 9101, Quincy, MA 022690-9101.
- 6.j. Do not use a welding power source for pipe thawing.

**CYLINDER MAY EXPLODE IF DAMAGED.**

- 7.a. Use only compressed gas cylinders containing the correct shielding gas for the process used and properly operating regulators designed for the gas and pressure used. All hoses, fittings, etc. should be suitable for the application and maintained in good condition. 
- 7.b. Always keep cylinders in an upright position securely chained to an undercarriage or fixed support.
- 7.c. Cylinders should be located:
 - Away from areas where they may be struck or subjected to physical damage.
 - A safe distance from arc welding or cutting operations and any other source of heat, sparks, or flame.
- 7.d. Never allow the electrode, electrode holder or any other electrically "hot" parts to touch a cylinder.
- 7.e. Keep your head and face away from the cylinder valve outlet when opening the cylinder valve.
- 7.f. Valve protection caps should always be in place and hand tight except when the cylinder is in use or connected for use.
- 7.g. Read and follow the instructions on compressed gas cylinders, associated equipment, and CGA publication P-1, "Precautions for Safe Handling of Compressed Gases in Cylinders," available from the Compressed Gas Association, 14501 George Carter Way Chantilly, VA 20151.

**FOR ELECTRICALLY POWERED EQUIPMENT.**

- 8.a. Turn off input power using the disconnect switch at the fuse box before working on the equipment.
- 8.b. Install equipment in accordance with the U.S. National Electrical Code, all local codes and the manufacturer's recommendations.
- 8.c. Ground the equipment in accordance with the U.S. National Electrical Code and the manufacturer's recommendations.

Refer to
<http://www.lincolnelectric.com/safety>
for additional safety information.

Technical Specifications HELIX M85 WELD HEAD	A-1
Safety Precautions	A-2
Proper handling	A-2
Operation.....	A-2
HELIX M85 WELD HEAD	A-3
Basic Information.....	A-3
Basic Components	A-3
Body Assembly.....	A-3
Torch Motion Assembly	A-3
Torch Assembly	A-4
Torch Consumables.....	A-5
Tracks.....	A-6
Track Ring Installation	A-7
Flat Track Installation	A-8
Weld Head Installation	A-8
Weld Head Positioning.....	A-8
Weld Head Setup	A-8
Torch Placement.....	A-8
Latch Tension	A-9
Clamp Latch Adjustment	A-10
Checking Clutch Latch Tension	A-10
Clutch Latch Tension Adjustment	A-11
Operational Safety Precautions	B-1
Operation Information.....	B-1
External inputs	B-1
Control.....	B-1
Welding Power	B-1
Manual Adjustments	B-1
Accessories	C-1
Torch Accessories	C-1
Maintenance.....	D-1
Maintenance Schedule.....	D-1
Every Shift.....	D-1
Monthly.....	D-1
Semi Annually	D-1
Tools.....	D-1
Trouble Shooting.....	F-1
Wiring Diagram	G-1
Dimensions Diagram.....	G-2
Helix M85 Parts Manual.....	P-1

Technical Specifications HELIX M85 Weld Head

HELIX M85 Weld head
 Product Number
 K52101-1

Input Power	24 VDC
Radial Clearance	8.5" (215.9 mm)
Axial Clearance	
Total Depth	9.94" (252.5 mm) +/- 1.0" (25.4 mm)
Center of Torch to rear	14.72" (373.9 mm) +/- 1.0" (25.4 mm)
Center of Torch to front	1.7" (43.2 mm)
Travel Speed	0.1 - 120 ipm
Max Oscillation Speed	150 ipm (3,810 mmpm)
Oscillation stroke	2" (50.8 mm)
Work Angle	+60 degrees in / -30 degrees out
Lead Lag	360 degrees
Torch Amps	Variable (Based on Power Supply)
Pipe Sizes	6" OD to Flat Track and 36"+ ID or 36"- ID

Weld Head Physical Dimensions

Length (handle to handle) 14.25" (362 mm)	Height 8.33" (211.6 mm)	Depth (minus the torch) 6.85" (174 mm)	Weight 25 lbs (11.3 kg)
--	----------------------------	---	----------------------------

Environmental

Operating Temperature Range 32°F to 140°F (0C - 60C)	Storage Temperature Range -22°F to 140°F (0C - 60C)
---	--

Ingress Protection - IP00

Explanation of Symbols



Electric Shock Warning



Hot Surface Warning

Safety Precautions

Read entire manual before installation or operation.



WARNING



Electric shock can kill

- Only qualified personnel should perform this installation.
- Turn the input power OFF at the disconnect switch or fuse box before working on this equipment

turn off the input power to any other equipment connected to the welding system at the disconnect switch or fuse box before working on the equipment.

- Do not touch electrically hot parts.
- Always connect the power supply grounding lug to a proper safety (Earth) ground.

Proper Handling

The HELIX M85 weld head is only meant to be picked up and supported by the handles. Only attempt to attach the weld head to the track ring while the clamp mechanism and clutch latch are disengaged.

Do not hang persons or objects from the handles of the weld head while operating.

Keep machine dry. Shelter from rain and snow. Do not place on wet ground or in puddles.

Always place the weld head on a steady, flat level surface when not in use or not clamped onto a track ring. Always be sure to engage the clutch latch when the weld head is left on the track.

Do not force the torch motion assembly in or out manually. Manually adjusting the torch in this manner can cause undue wear and tear on the gear and motors.

After welding allow adequate time for the weld head to cool before moving, making adjustments or putting into storage.

Operation

Read entire manual before operation.

Only operate while firmly attached to the track ring with the clutch latch engaged. Always verify that the track is properly attached to the work surface before operating.

Keep hands away from weld head while in operation.

Verify that the system cable assembly is free from obstruction before operating. While welding, the weld head will rotate around the pipe. Be certain that there is plenty of play in weld cable. If the cable binds up during welding, parts of the weld cable or the weld head assembly may become damaged.

Never unplug or plug in control cables to the weld head while the system is powered on.

Verify that the system is properly grounded before beginning to weld.

HELIX M85 Weld Head

Basic Information

The HELIX M85 weld head is a precision, digitally controlled weld head for multi-process welding. These processes are set by the power supply. Designed to work with the APEX® 3 Series Orbital Controllers, the HELIX M85 weld head can weld pipes size 6 in (152.4 mm) OD and larger. It can also weld inside diameters starting at 36 in (914.4 mm) and on flat track. The HELIX M85 weld head has multiple quick-release tracking ring and stand-off options that allow the operator many choices for welding pipes. The track rings are provided separately.

The HELIX M85 weld head has automatic height control, oscillation capabilities, and multiple toolless torch adjustment options. These give the operator greater control of the weld puddle for more complicated welds.

Basic Components

The three basic components of the weld head are:

- Body Assembly
- Torch Motion Assembly
- Torch Assembly

See **FIGURE 1 - Weld Head Components** – for the different weld head components.

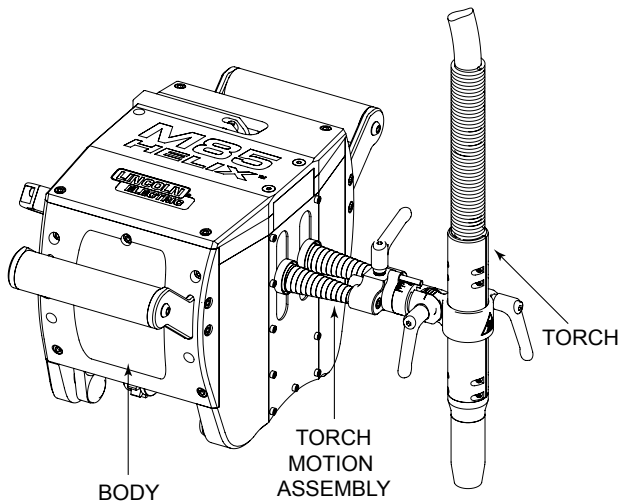

FIGURE 1 - Body Assembly (Front)

Each of the weld head components are discussed separately.

Body Assembly

The body assembly is the main assembly for the HELIX M85 weld head. It contains the travel gears, motors and belts that provide motion and oscillation for the weld head – see **FIGURE 2 - Body Assembly**.

Adjustments and controls located on the body include:

- **Clutch Latch**
This latch engages or disengages the clutch to allow for free motion along the track.
- **Clamp Latch**
This latch engages or disengages the clamp which secures the weld head onto the track.
- **Control Cable Input**
A connecting point for the control cable which delivers all signals to the weld head.
- **Torch Cable Arrestor**
The component that secures the torch cable and maintains the correct amount of tension or bend in it.

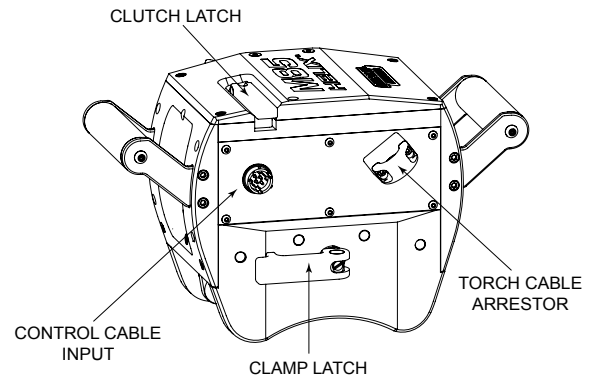

FIGURE 2 - Body Assembly (Rear)

Torch Motion Assembly

The torch motion assembly provides all manual adjustments and movements for the torch – see **FIGURE 3 - Torch Motion Assembly**.

The torch motion assembly consists of:

- **Telescoping Covers**
These covers (bellows) provide protection for the torch components, preventing dirt or other harmful substances from entering the weld head.
- **In/Out, Travel Angle Adjustment Lever**
This single adjustment lever allows the operator to physically adjust the torch closer or further from the weld head and also adjust the travel angle. There is no maximum amount of adjustment for the lead/lag.

• **Travel Angle Stop**

The travel angle stop is an adjustable stop that can be used to quickly bring the travel angle back to a preset position.

• **Torch Tilt Assembly**

This component is removable and comes in various sizes. It can be used for multiple applications.

• **Work Angle Adjustment Lever**

The work angle can be adjusted to a positive 60 degrees or a negative 30 degrees.

• **Torch Height Adjustment Lever**

The torch can be physically adjusted up or down as needed by the operator.

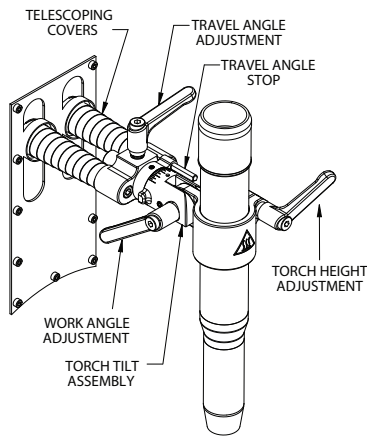

FIGURE 3 - Torch Motion Assembly

FIGURE 4 - Torch Assembly Parts

1. Torch Cable
2. Torch Body Half
3. Nozzle Bushing
4. Diffuser
5. Contact Tip
6. Nozzle
7. Wire Liner
8. Coupler
9. Connector Assembly

Torch Assembly

The torch assembly is a straight-barrel version of the Magnum® Pro Gun that is specifically designed for mechanized welding. It can be broken down into several pieces – **FIGURE 4 - Torch Assembly**.

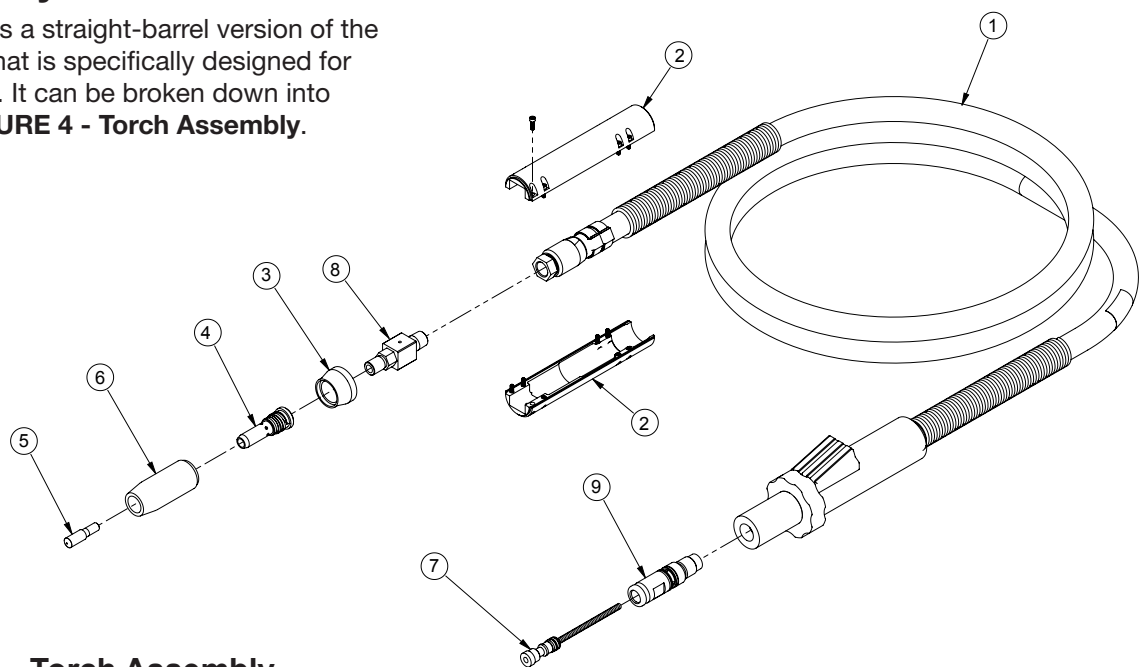

FIGURE 4 - Torch Assembly

Liner Installation

Installation of KP45 - []

- a. Lay the gun and cable straight on a flat surface.
- b. Make sure that the set screw in the connector end is backed out so as not to damage the liner or the liner bushing. Remove and save the gas nozzle, nozzle bushing and gas diffuser from the end of the gun assembly.
- c. Insert a new untrimmed liner into the connector end of the cable. Be sure the liner bushing is stenciled appropriately for the wire size being used.
- d. Tighten the set screw.
- e. Be sure the cable is straight. Trim the liner to a length of approximately 9/16" (14.3 mm) past the coupler. Remove any burrs from the end of the liner.
- f. Screw the gas diffuser onto the end of the coupler and tighten.
- g. Replace the nozzle bushing and gas nozzle.

CONTACT TIP AND GAS NOZZLE INSTALLATION

- a. Choose the correct size contact tip for the electrode being used (wire size is stenciled on the side of the contact tip) and screw it snugly into the gas diffuser.
- b. Install the appropriate gas nozzle onto the diffuser. The proper nozzle should be selected based on the welding application. Choose the gas nozzle as appropriate for the process to be used. Typically, the contact tip end should be flush to 1/8" (3.2 mm) extended for the short-circuiting transfer process for all three and .12" (3.1mm) recessed for spray transfer. For the FCAW-G process, 1/8" (3.2 mm) recess is recommended.

CONNECTION TO FEEDER

- a. Check that the drive roll(s) and the feeder guide plate is appropriate for the electrode size being used.
- b. Fully push the brass connector end of the gun cable into the conductor block on the outgoing side of the feeder wire drive. Secure the cable using the hand screw or set screw in the conductor block.

AVOIDING WIRE FEEDING PROBLEMS

Wire feeding problems can be avoided by observing the following gun handling procedures:

- a. Do not kink or pull cable around sharp corners.
- b. Keep the electrode cable as straight as possible when welding or loading electrode through cable.
- c. Avoid wrapping excess cable around handle or front of wire feeder especially on longer 20 and 25 ft (6.1 and 7.6 m) length guns.
- d. Do not allow dolly wheels or trucks to run over cables.
- e. Keep cable clean by following maintenance instructions.
- f. Use only clean, rust-free electrodes. To better ensure proper surface lubrication, we recommend using only Lincoln Electric brand electrodes.
- g. Replace contact tip when the arc starts to become unstable or the contact tip end is fused or deformed.

IMPORTANT!

- a. Replace worn contact tips as required.
- b. Remove spatter from inside of gas nozzle and from tip after each 10 minutes of arc time or as required.

GUN CABLES

CABLE CLEANING

Clean cable liner after using approximately 300 pounds (136 kg) of electrodes. Remove the cable from the wire feeder and lay it out straight on the floor. Remove the contact tip from the gun. Using an air hose and only partial pressure, gently blow out the cable liner from the gas diffuser end.



Excessive pressure at the start may cause the dirt to form a plug.

Flex the cable over its entire length and again blow out the cable. Repeat this procedure until no further dirt comes out.

Tracks

The HELIX M85 weld head was designed to work with the Lincoln Electric patented track system. These tracks are available as either flat tracks or rings.

There are two varieties of track rings. One works for welding the outside diameter of pipes; the other is used for welding on the inside of pipes.

Outside Diameter (OD) track rings – see **FIGURE 5 - OD Diameter Track Ring** – are quick-release track rings made for quick installation and removal from pipes.

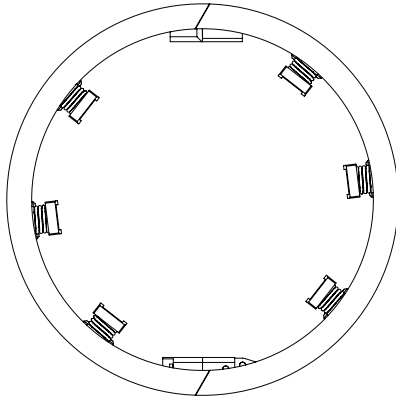

FIGURE - 5 OD Diameter Track Ring

Quick-release track rings are closed or opened using two latches – see **FIGURE 6 - Latches**. These latches are designed to hook easily and keep the track ring closed. The hooks stay out of the way when the tractor is in motion.

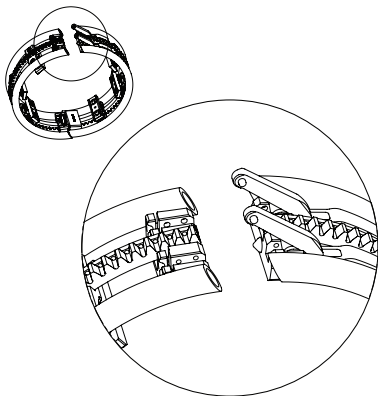

FIGURE 6 - Latches

Refer to the table for standard track sizes as well as the track shoes and stand offs that are available.

Outside Diameter (OD) Quick-Release Track Rings		Part Number
Track Ring 12"		K52000-12
Track Ring 14"		K52000-14
Track Ring 16"		K52000-16
Track Ring 18"		K52000-18
Track Ring 20"		K52000-20
Track Ring 22"		K52000-22
Track Ring 24"		K52000-24
Track Ring 28"		K52000-28
Track Ring 32"		K52000-32
Track Ring 36"		K52000-36
Track Ring 40"		K52000-40
Track Ring 44"		K52000-44
Track Ring 48"		K52000-48
Track Ring 52"		K52000-52
Track Ring 56"		K52000-56
Track Ring 60"		K52000-60
Track Ring 64"		K52000-64
Larger sizes can be made to order. For inquiries please call: 1-800-770-0063 or email at orbitalsales@lincolnelectric		
OD (Outside Diameter) Quick-Release Standoffs		Part Number
Quick-Release Shoe Extension 0.5"		K52060-05
Quick-Release Shoe Extension 1.0"		K52060-10
Quick-Release Shoe Extension 2.0"		K52060-20
Quick-Release Shoe Extension 3.0"		K52060-30
Flat Tracks		
48" Flat Track		K52083-48
Magnetic Shoe		K52089-1
48" Flat Track w/ 3 Mag Shoes		K52090-1
Inside Diameter (ID) Track Rings		
These components are made to order. For inquiries please call: 1-800-770-0063 or email us at: orbitalsales@lincolnelectric		

Track Ring Installation



HOT SURFACE WARNING!
After a weld, allow enough time for the track and work surface to cool before removing it or installing a new track configuration.

To install the track ring:

With the track open, place the portion of the track with the latches on top of the pipe surface. See **FIGURE 7 - Track Ring Placement** for proper placement.

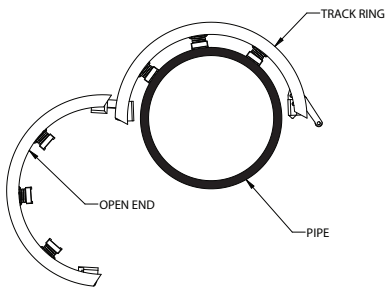

FIGURE 7 - Track Ring Placement

Putting the track ring in this position allows the operator to bring the hanging portion of the track up to the latches. With the latches hanging freely – see **FIGURE 8 - Latch Positions** – the operator can slide the latch catches into the notches. Doing this will hook the track in place without the need to employ the latches. Engage the latches by pulling up on each latch until they sit recessed along the track ring.

NOTE: It is possible to install the track in the reverse method, however this method can result in damage to the pipe.

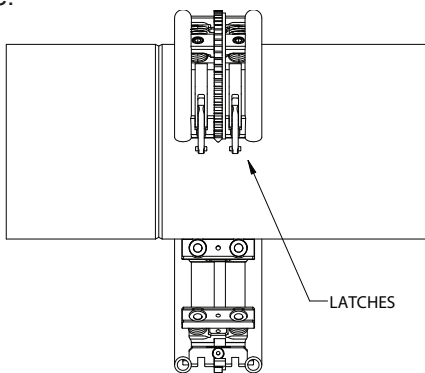

FIGURE 8 - Latch Positions

Position the track ring approximately 8.5" (21.6 cm) away from the joint. With the track positioned correctly and the latches engaged, tighten the track shoes.

Tighten only opposite-facing track shoes and make sure each shoe is tightened to the same degree, ensuring that the track ring will sit correctly around the pipe.

Verify that the track ring shows an equal amount of space at points of the pip – see **FIGURE 9 - Proper Track Ring Spacing**.

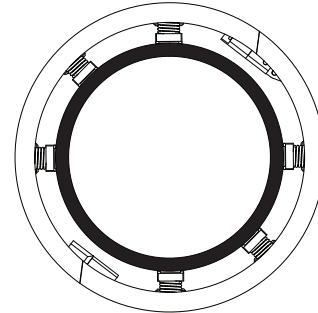

FIGURE 9 - Proper Track Ring Spacing

Tightening the weld shoes unevenly on each side can result in the ring being off center – see **FIGURE 10 - Improper Track Ring Spacing**. Improper track ring spacing can also result from an out-of-round pipe.

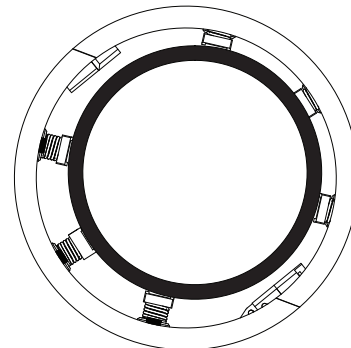

FIGURE 10 - Improper Track Ring Spacing

Flat Track Installation

The flat track is installed parallel to the joint, approximately 8.5" (21.6 cm) away. When using magnetic track shoes, position the track before engaging the magnets. To engage the magnets, turn on the switch – see **FIGURE 11 - Flat Track Magnetic Switch**. Flat tracks can be combined to achieve the required length.

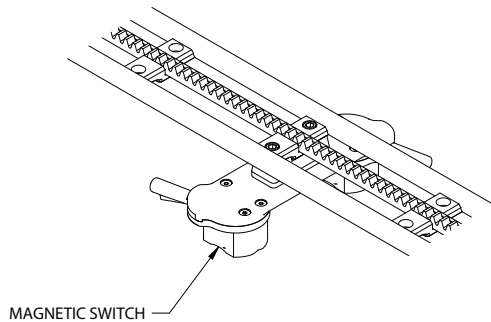

FIGURE 11 - Flat Track Magnetic Switch

Weld Head Installation

Once the appropriate track is installed, the weld head is ready to be put in place. Disengage both the clutch latch and the clamp latch. Moving the weld head by the handles, place the tractor onto the track– see **FIGURE 12 - Weld Head Placement**. With the weld head sitting on the track, engage the clamp latch. The weld head should move freely along the track. Now engage the clutch latch. If necessary, move the weld head slightly to align the gear teeth when engaging the clutch. Check to be sure that the weld head does not move with both latches engaged.

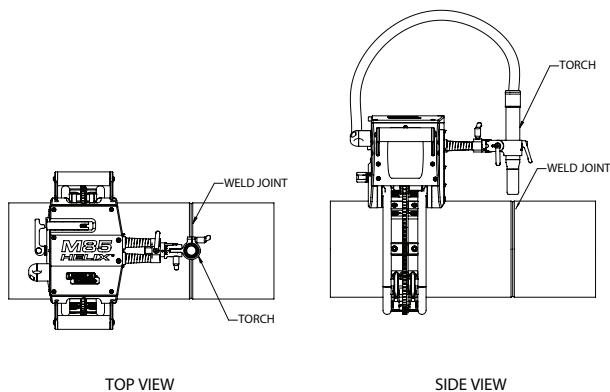

FIGURE 12 - Weld Head Placement

Weld Head Positioning

Align the weld head at the correct starting position for the weld. The weld head can be moved freely around the track by disengaging the clutch latch. Confirm the clutch latch is re-engaged before welding.

Weld Head Setup

Torch Placement

With the HELIX M85 weld head in place, the torch needs to be in the proper location. There are toolless adjustments that make positioning the torch easier.

Make certain that all of the following adjustments are performed after the weld head has had sufficient time to cool.

Torch Height Adjustment

Using the torch height adjustment lever, the operator can move the torch up or down – see **FIGURE 13 - Torch Height Adjustment**.

Adjust the torch up or down to the correct height by turning the lever counter-clockwise. Move the torch to the desired position. Once positioned, tighten the lever by turning clockwise.

Make sure that the torch is set in a position where the motorized height control can reach the bottom of the joint and retract far enough back for the final cap pass.

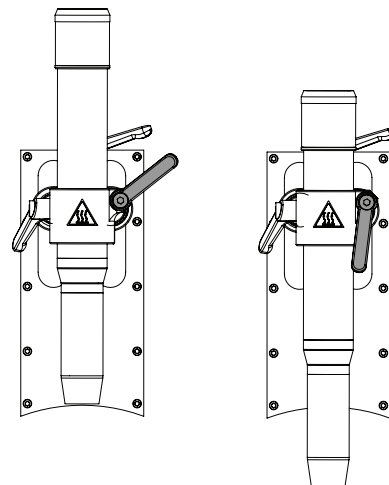

FIGURE 13 - Torch Height Adjustment

Work Angle Adjustment

The HELIX M85 weld head allows for 60 degrees of outward adjustment and 30 degree of inward adjustment. This angle can be changed by using the work angle adjustment – see **FIGURE 14 - Work Angle Adjustment**.

Change the position to the correct angle and then tighten the lever to lock the angle into place.

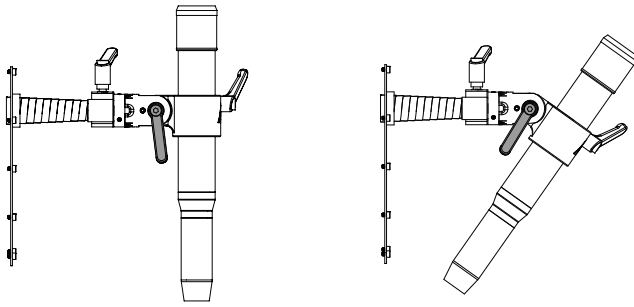

FIGURE 14 - Work Angle Adjustment

Travel Angle Adjustment

The travel angle adjustment lever serves two functions. First, it enables the operator to adjust for lead and lag – see **FIGURE 15 - Travel Angle Adjustment**. Second, it allows the torch to be moved in and out – see **FIGURE 16 - Torch In/ Out**. This can vary depending on the length of the rod on the torch tilt assembly.

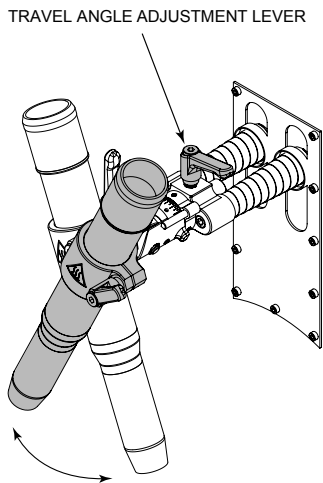

FIGURE 15 - Travel Angle Adjustment

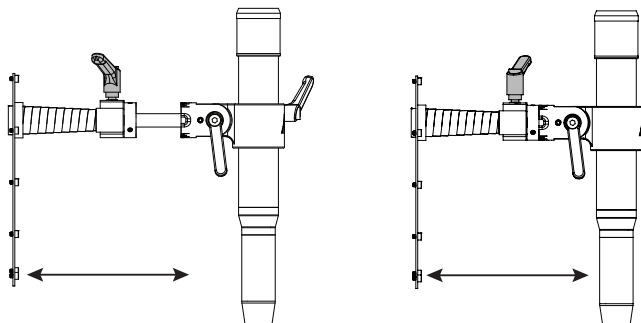

FIGURE 16 - Torch In/ Out

A specific travel angle adjustment position can be rapidly achieved using the lead lag stop. This is an adjustable ring that helps the operator locate the same angle each time they adjust the torch. To adjust the travel angle stop, loosen the screw on the side of the stop (see **FIGURE 17 - Travel Angle Stop**). Move the indicator to the desired position and retighten the screw.

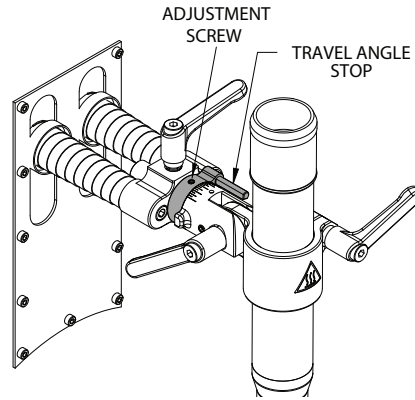

FIGURE 17 - Travel Angle Stop

Latch Tension

The clamp latch and clutch latch tension for the HELIX M85 weld head are adjustable. This adjustment may need to be done when moving from a flat track to a track ring and also during extended hours of continual service.

Checking Clamp Latch Tension

To determine if the clamp latch is set correctly, attach the weld head to the track surface and engage it. Do not engage the clutch latch, or if it is engaged, disengage it. Keep a firm hold on the tractor while testing. Move the tractor back and forth and use the following guidelines to determine if the clamp latch is too tight, too loose or if it is at the correct tension.

Tight

The weld head is too tight if it does not move smoothly around the track. This may mean that it requires a moderate amount of force to move the weld head. Movement should be effortless.

Loose

The weld head is too loose if moves freely but has side to side rotational movement – see **FIGURE 18 - Clamp Latch Movement**.

Correct

The clamp latch is at the correct tension when the weld head is latched in place and the tractor travels smoothly across the track with no effort. In addition, there will not be any side-to-side rotational movement.

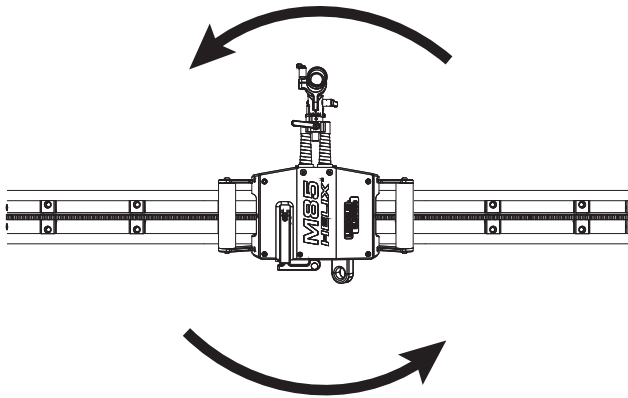

FIGURE 18 - Clamp Latch Movement

Clamp Latch Tension Adjustment

1. The first step in adjusting the clamp latch tension will be to loosen the set screw on the bottom of the latch assembly, see **FIGURE 19 - Latch Set Screw**.

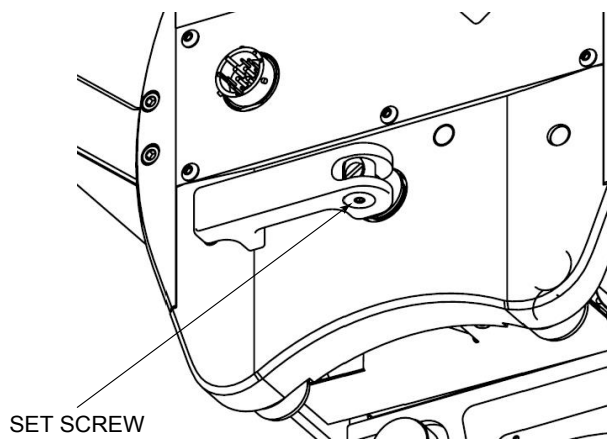

FIGURE 19 - Latch Set Screw

2. Then loosen the secondary set screw on the underside of the HELIX M85, see **Figure 20 - Secondary Clamp Set Screw**.

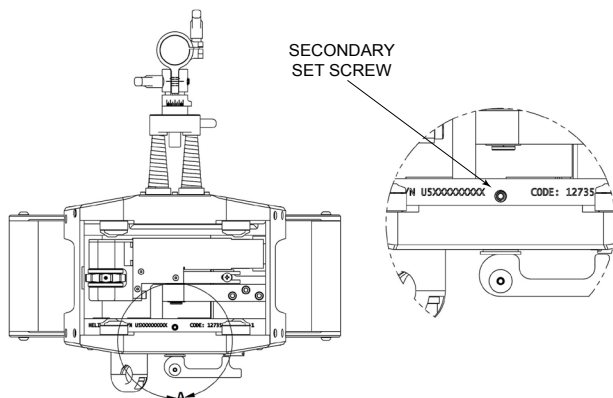

FIGURE 20 - Secondary Clamp Set Screw

3. Once the set screws have been loosened, adjust the tension using a flat-head screwdriver to turn the adjustment screw – see **FIGURE 21 - Adjustment Screw**.

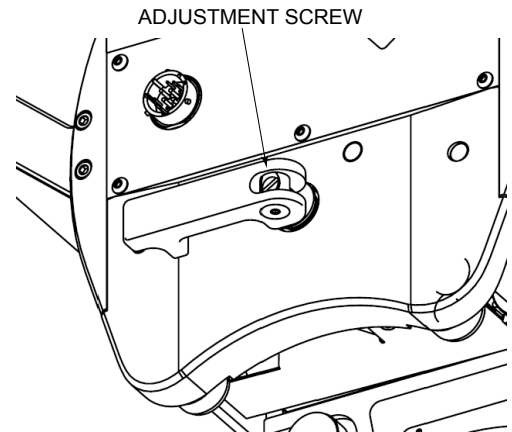

FIGURE 21 - Adjustment Screw

Turn the adjustment screw clockwise to increase the tension. Turning it counterclockwise will decrease the tension.

4. Test the tension by placing the weld head back on the track.
5. Once the desired tension is achieved, tighten the set screws to lock it in. Be sure not to over tighten the set screws.

Checking Clutch Latch Tension

If the clutch latch is too tight it will not be able to ride over debris on the gear. If it is too loose then there will be slop in the travel position of the weld head.

Tension for the clutch latch requires a visual inspection of the gear assembly in relation to the track gear – see **FIGURE 22 - Track Gear Interaction**. Using a flashlight, visually verify that the drive gear shoulder touches the track gear shoulder. Using a flat-head screwdriver, lift the gear off the track. It should move up 1/8". If it moves farther, the clutch latch will need to be tightened. If it does not move up, the clutch latch will need to be loosened.

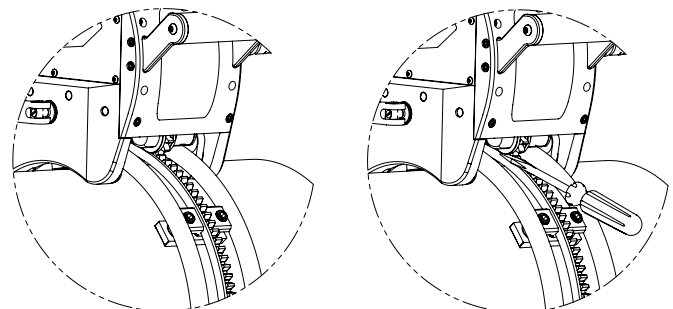

FIGURE 22 - Track Gear Interaction

Clutch Latch Tension Adjustment

1. To adjust the clutch latch tension, use a flat-head screwdriver to turn the adjustment screw – see **FIGURE 23 - Adjustment Screw**. Turn the adjustment screw counterclockwise to increase the tension, turn clockwise to decrease the tension.
2. Be sure to test the tension by placing the weld head back on the track and engaging the clutch latch.

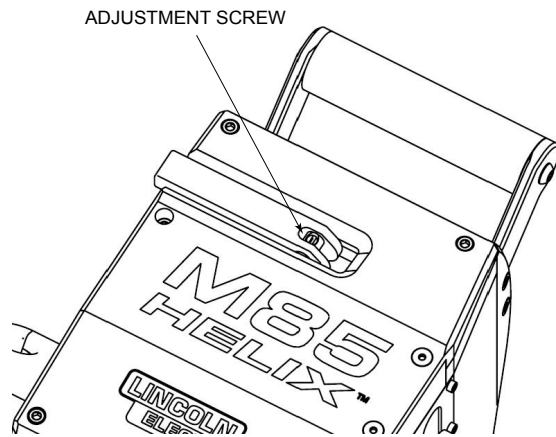
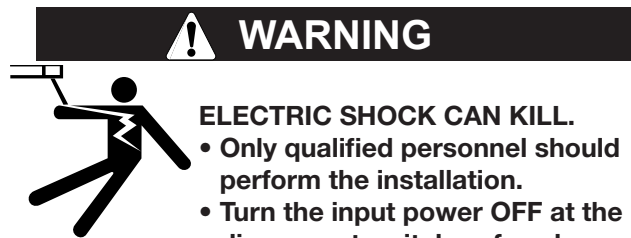

FIGURE 23 - Adjustment Screw

Operational Safety Precautions

Read and understand this entire section before operating the machine.



ELECTRIC SHOCK CAN KILL.

- Only qualified personnel should perform the installation.
- Turn the input power OFF at the disconnect switch or fuse box.
- Do not touch electrically live parts or electrode with skin or wet clothing.
- Insulate yourself from work and ground.
- Always dry insulating gloves.
- Read and follow “Electric Shock Warnings” in the Safety section if welding must be performed under electrically hazardous conditions such as welding in wet areas or on or in the work pieces.



FUMES AND GASES can be dangerous.

- * Keep your head out of fumes.
- * Use ventilation or exhaust to remove fumes from breathing zone.

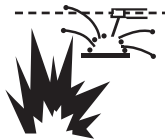

WELDING SPARKS can cause fire and explosion

- * Keep flammable material away.
- * Do not weld on containers that have held combustibles.



ARC RAYS can burn.

- * Wear eye, ear and body protection.

Observe additional Safety Guidelines detailed in the beginning of this manual.

Refer to control system manual for all operational instructions.

Operation Information

The HELIX M85 weld head is designed for multi-process welding and will work with any APEX® 3 Series Orbital Control System. For complete installation and operational instructions, see the specific controller manual and the applicable process manual.

External inputs

The external inputs for the M85 weld head are control signals, and 24V DC.

Control

Control of the weld head and wire feeder is provided by the APEX 3 Series controller. Through the use of a handheld pendant, the operator is able to control and monitor all aspects of the weld and change parameters while welding.

Welding Power

Welding power is provided by a standard Lincoln Electric Power Wave® or a Vantage® power source. An ArcLink connection is required.

Manual Adjustments

Manual adjustments for the M85 weld head include: changing the track ring, repositioning the weld head on the workpiece, all torch placement adjustments, and changing out all consumable parts and pieces.

Before operation, check all coolant cables for leaks, and all cables for fraying or loose connections or damage. All consumables should be changed out per shift. Operating welding equipment with incorrect or broken consumables can cause bodily harm or damage to the machine.

Accessories

HELIX M85 Accessories and Consumables

Accessory	Part Number
Weld Head Control Cable 25'	K52107-25
Weld Head Control Cable 50'	K52107-50
Mechanized Torch 25 ft. (7.6 m)	K52106-25
Mechanized Torch 15 ft. (4.6 m)	K52106-15
Oscillation Cover Kit (Bellows)	KP52135-1
Replacement Belt Package Oscillation	KP52137-1
Replacement Belt Package Height	KP52136-1
Contact Tip 0.045	KP2745-045R
Gas Diffuser	KP2747-1
Gas Nozzle 1/8 in. Recessed	KP2743-1-62R
Gas Nozzle 1/8 in. Stick Out	KP2743-1-62S
Nozzle Bushing	KP52144-1
Wire Liner 0.030 - 0.045 in. (0.76 - 1.14mm) 15 ft. (4.6 m)	KP45-3545-15
Wire Liner 0.030 - 0.045 in. (0.76 - 1.14mm) 25 ft. (7.6 m) Length	KP45-3545-25
Wire Liner 0.052 - 1/16 in. (1.3 - 1.6 mm) 15 ft. (4.6 m) Length	KP45-116-15
Wire Liner 0.052 - 1/16 in. (1.3 - 1.6 mm) 25 ft. (7.6 m) Length	KP45-116-25

Maintenance

The HELIX M85 weld head is designed for trouble-free operation and normally requires minimal preventive care and cleaning. This section provides instructions for maintaining user-serviceable items. The suggested repair procedure for all such items is to remove and replace defective assemblies or parts.

When users and/or service personnel are not familiar with electrical and electronic equipment, the product should be returned to the factory or serviced by factory authorized representatives.

Maintenance Schedule

The maintenance schedule is suggested as a guideline for proper system maintenance. More stringent maintenance requirements may be required depending on the work being performed and the requirements of the customer for whom the work is performed. All maintenance schedules are based on a 40-hour work week.

Any excess play in parts or equipment should be noted and reported to an authorized repair facility. Any anomalous activity, such as motor hesitation, clicking or other noises, or anything out of the ordinary should be noted and reported to an authorized repair facility.

Every Shift

- Check lines, cables, and drive belts for loose connections and worn areas.
- Change out consumables as needed.
- Check torch height motion and travel for slop or wearing parts.
NOTE: Do not force the oscillator in or out while checking for worn parts.
- Inspect torch cable for wear or damage.

Monthly

- Apply a type of high temperature lubricant or anti-spatter spray to the bellows every 30 days or as needed.
- With the clutch latch and clamp latch engaged, grab the weld head by the handles and gently move back and forth to check for excess play in the weld head along the track.
- Release the clutch latch and verify that the weld head moves smoothly along the track without rubbing or binding.
- Examine all cable connections to verify that there are no gas leaks, and that all cables are seated correctly and that there is no visible wear and tear to any connector or associated cables.

- Check over the all weld head components for any signs of damage or wearing.
- Ensure track ring gears and weld head gears are clean and clear of debris.
- Check for wear of drive rolls on wire feeder.

Semi Annually

- Based on a 40-hour work week it is recommended that the belts be replaced every six months.
- Verify that all motors are working correctly without strain. Listen to the motors to confirm that there is no excess noise or grinding.

Tools

Required tools to operate and repair the HELIX M85 weld head:

- 2.5 mm hex key
- 3 mm hex key
- 4 mm hex key
- 6 mm hex key
- wire cutters
- flat-head screwdriver

Further tools are required for in depth maintenance which is only authorized at local repair facilities.

Observe all Safety Guidelines detailed throughout this manual.

PROBLEMS (SYMPTOMS)	POSSIBLE CAUSE	RECOMMENDED COURSE OF ACTION
Auto Height does not operate / operates incorrectly.	<ol style="list-style-type: none"> 1. Check WFS/Amps 2. Check auto height is on. 3. Check wire. 4. Check contact tip. 	
Travel hesitates or does not work.	<ol style="list-style-type: none"> 1. Check clutch latch to ensure it is engaged (locked). 2. Check all cable connections. 	
Travel is inconsistent.	<ol style="list-style-type: none"> 1. Check gear contact and lever. 2. Check travel settings. 	
No oscillation / inconsistent oscillation.	<ol style="list-style-type: none"> 1. Check all cable connections. 2. Check oscillator settings on jog screen. 3. Check bellows for free movement. 3. Check oscillator belt. 	
Wire does not feed properly.	<ol style="list-style-type: none"> 1. Check drive rolls 2. Check wire feed for blockage. 3. Check contact tip. 4. Check for kinks or obstructions in the torch or wire liner. 	
Gas issues	<ol style="list-style-type: none"> 1. Verify gas is turned on. 2. Verify there is gas present in the tank. 3. Check the gas line for kinks or obstructions. 	
Tractor drags on work surface	<ol style="list-style-type: none"> 1. Check that the shoes are all equally spaced around the track. 	
<p style="text-align: center;">If all recommended possible areas of misadjustment have been checked and the problem persists, Contact your local Lincoln Authorized Field Services Facility.</p>		

⚠ CAUTION

If for any reason you do not understand the test procedures or are unable to perform the tests/repairs safely, contact your **Local Lincoln Authorized Field Service Facility** for technical troubleshooting assistance before you proceed.

Wiring Diagram

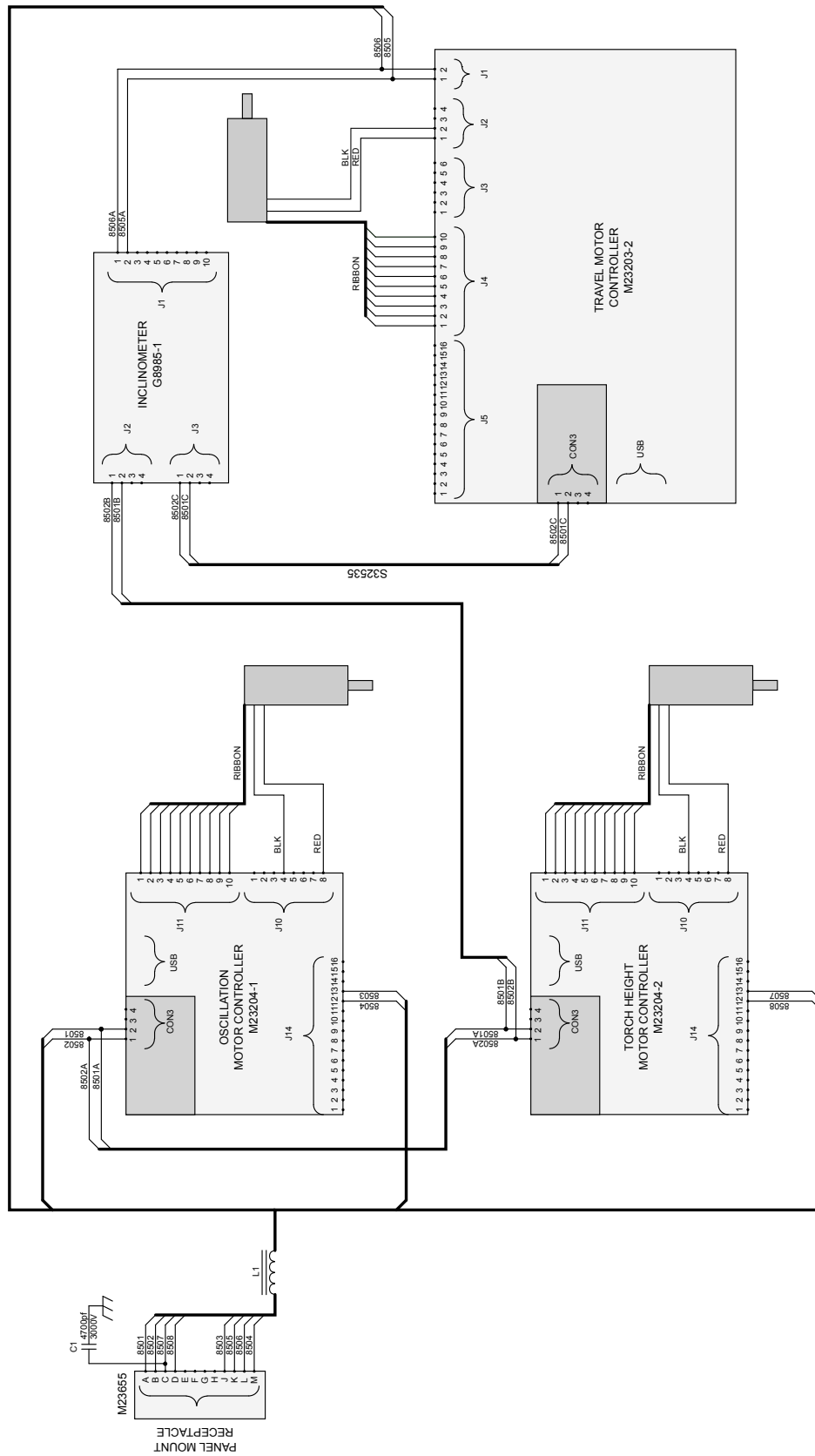

NOTE: This diagram is for reference only. It may not be accurate for all machines covered by this manual. The specific diagram for a particular code is pasted inside the machine on one of the enclosure panels. If the diagram is illegible, write to the Service Department for a replacement. Give the equipment code number.

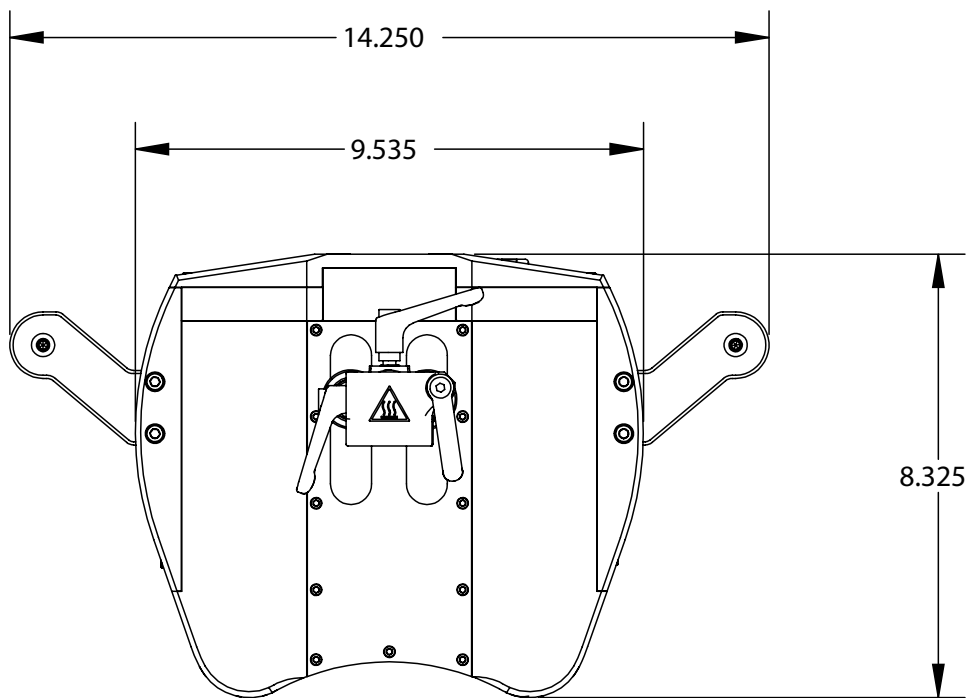
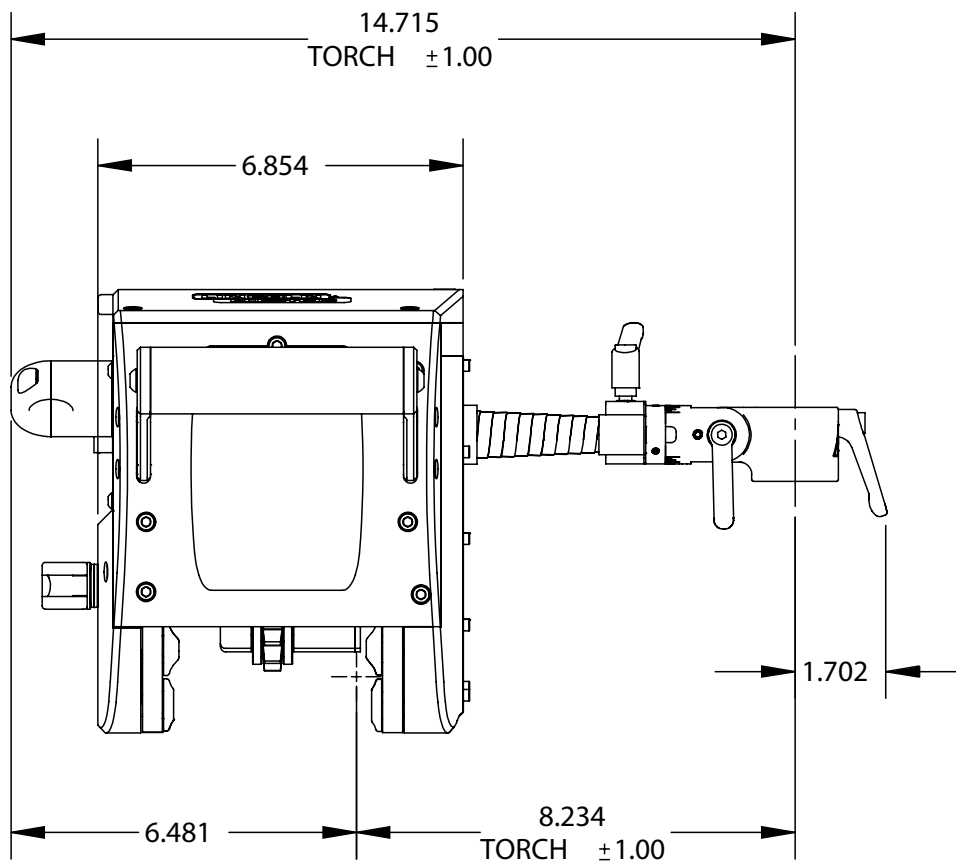

Dimensions

NOTE: This diagram is for reference only. It may not be accurate for all machines covered by this manual. The specific diagram for a particular code is pasted inside the machine on one of the enclosure panels. If the diagram is illegible, write to the Service Department for a replacement. Give the equipment code number.

P-788
GENERAL ASSEMBLY

HELIX® M85 WELD HEAD PARTS MANUAL

Code: 70315, 12735

This parts list is provided as an informative guide only.

Observe all Safety Guidelines detailed throughout this manual.

 **CAUTION**

If for any reason you do not understand the test procedures or are unable to perform the tests/repairs safely, contact your **Local Lincoln Authorized Field Service Facility** for technical troubleshooting assistance before you proceed.

P-788
Weld Head Side Panels

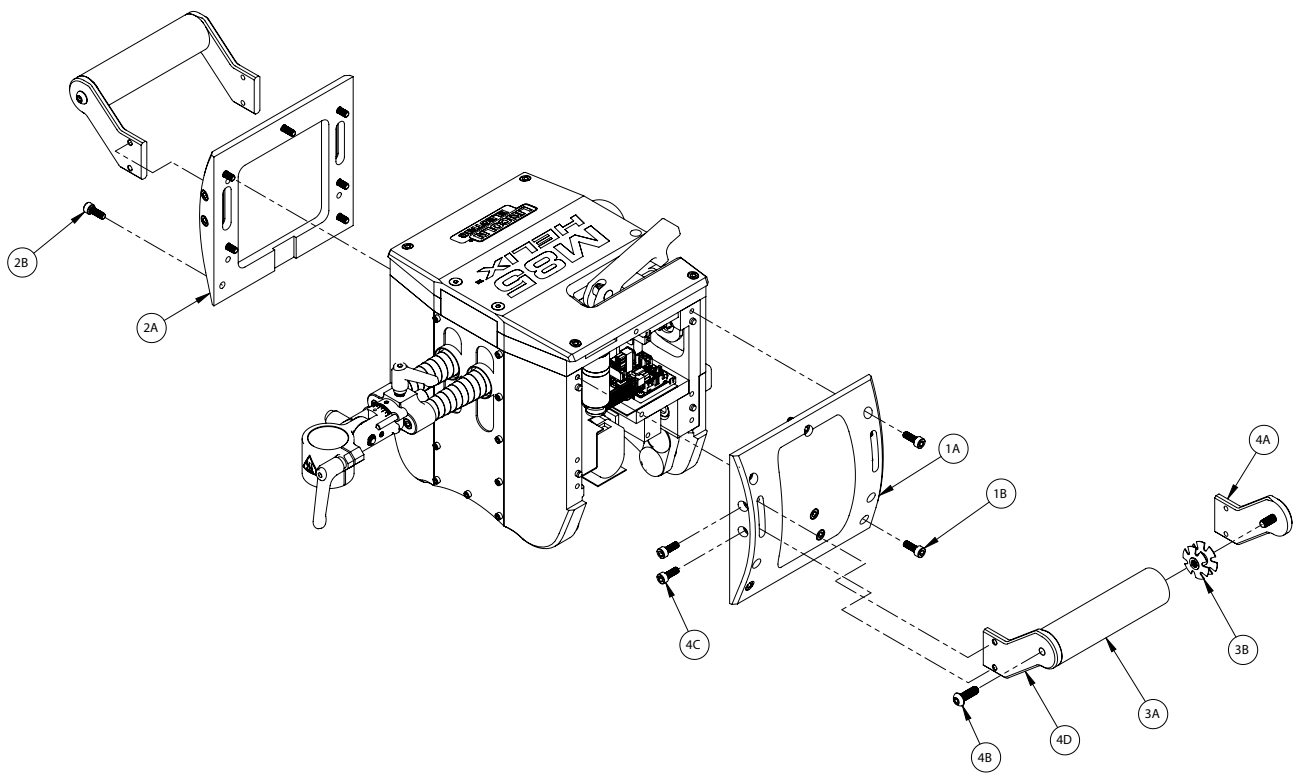

9-30-18

NOTE: This Parts Manual is provided as an informative guide only. When ordering parts, always refer to the Lincoln Electric Parts List.

Indicates a change in this printing.

Use only the parts marked "x" in the column under the heading number called for in the model index page.

ITEM	DESCRIPTION	PART NO.	QTY.	1	2	3	4	5	6	7	8	9
	M85 Weld Head Side Panels											
1	End Plate Left Assembly		1	x								
1A	End Plate Left (NFS)	9SM24379	1	x								
1B	Socket Head Cap Screw (NFS)		9	x								
2	End Plate Right Assembly		1	x								
2A	End Plate Right (NFS)	9SM24380	1	x								
2B	Socket Head Cap Screw (NFS)		9	x								
3	Handle Assembly		1	x								
3A	Handle (NFS)	9SS29769	1	x								
3B	Handle Inserts (NFS)		2	x								
4	Handle Bracket Assembly		1	x								
4A	Bracket A (NFS)		1	x								
4B	Screw (NFS)	9SS30726-3	2	x								
4C	Socket Head Cap Screw (NFS)		4	x								
4D	Bracket B (NFS)		1	x								

NOTE: This Parts Manual is provided as an informative guide only. When ordering parts always refer to the Lincoln Electric Parts List.

P-788
Weld Head Torch Motion

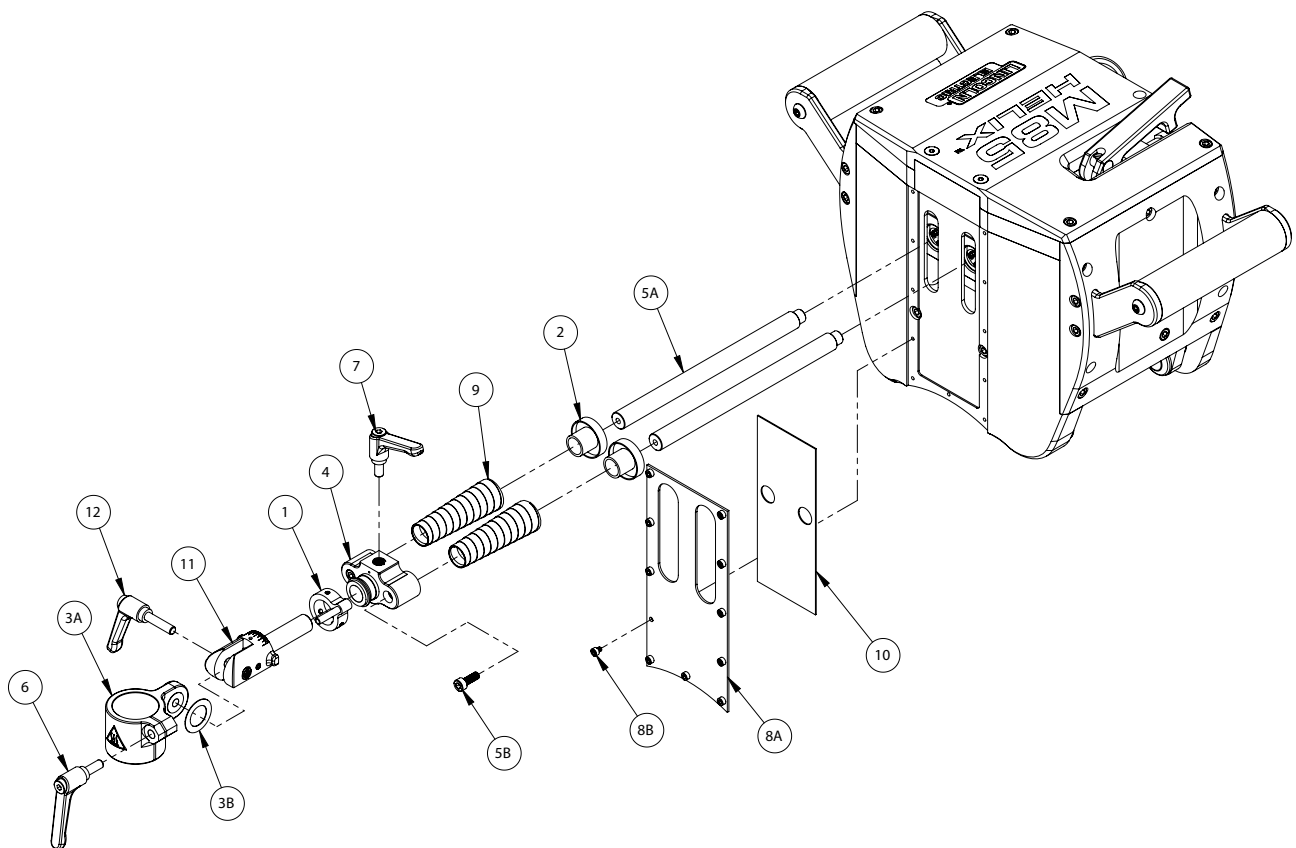

9-30-18

NOTE: This Parts Manual is provided as an informative guide only. When ordering parts, always refer to the Lincoln Electric Parts List.

P-788
Weld Head Torch Motion

Indicates a change in this printing.

Use only the parts marked "x" in the column under the heading number called for in the model index page.

ITEM	DESCRIPTION	PART NO.	QTY.	1	2	3	4	5	6	7	8	9
	Weld Head Torch Motion											
1	Torch Stop	9SM24556	1	x								
2	Bellows Retainer	9SM24561	2	x								
3	Torch Clamp Assy		1	x								
3A	Torch Clamp (NSS)	9SM24562	1	x								
3B	Washer (NSS)		2	x								
4	Torch Mount Assy	9SM24566	1	x								
5	Shaft Assy		1	x								
5A	Shafts (NSS)	9SS30339	2	x								
5B	Screws (not shown) (NSS)		4	x								
6	Up Down Adjustment Handle	9SS30501	1	x								
7	Lead Lag Adjustment Handle	9SS30503	1	x								
8	Spatter Shield Assembly		1	x								
8A	Spatter Shield (NSS)	KP52112-1	1	x								
8B	Screw (NSS)		11	x								
9	Oscillation Cover Kit (2 per kit)	KP52135-1	1	x								
10	Inner Cover	KP52138-1	1	x								
11	Torch Pivot Assy	KP52139-1	1	x								
12	Weld Angle Adjustment Handle	9SS30502	1	x								

NOTE: This Parts Manual is provided as an informative guide only. When ordering parts always refer to the Lincoln Electric Parts List.

P-788
Weld Head Clamping Assembly

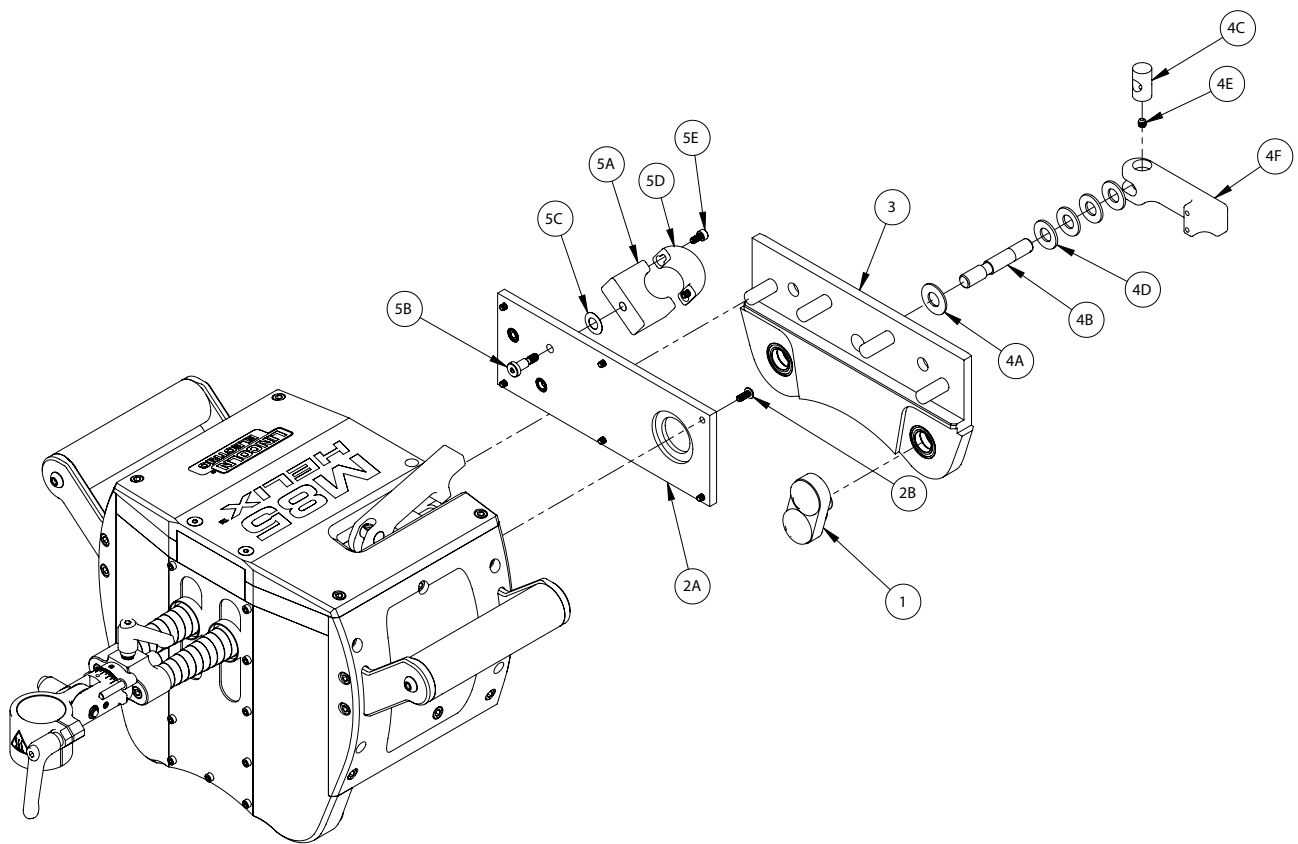

9-30-18

NOTE: This Parts Manual is provided as an informative guide only. When ordering parts, always refer to the Lincoln Electric Parts List.

P-788
Weld Head Clamping Assembly

Indicates a change in this printing.

Use only the parts marked "x" in the column under the heading number called for in the model index page.

ITEM	DESCRIPTION	PART NO.	QTY.	1	2	3	4	5	6	7	8	9
	Weld Head Clamping Assembly											
1	Roller Pivots	9SM22949	4	x								
2	Outer Cover Assy		1	x								
2A	Outer Cover (NFS)	9SM24378	1	x								
2B	Screw (NFS)		6	x								
3	Outboard Plate	9SM24558	1	x								
4	Clamp Lever Assy	9SS30726-1	1	x								
4A	Washer (NFS)		1	x								
4B	Shaft (NFS)		1	x								
4C	Cam Nut (NFS)		1	x								
4D	Spring Washer (NFS)		4	x								
4E	Set Screw (NFS)		1	x								
4F	Clamp Lever	9SM24419	1	x								
5	Cable Retainer Clamp Assy		1	x								
5A	Retainer Base (NFS)		1	x								
5B	Retaining Screw (NFS)		1	x								
5C	Washer (NFS)	9SS30726-4	1	x								
5D	Retainer Top (NFS)		1	x								
5E	Screw (NFS)		2	x								

9-30-18

NOTE: This Parts Manual is provided as an informative guide only. When ordering parts always refer to the Lincoln Electric Parts List.

P-788
Weld Head Top Panel

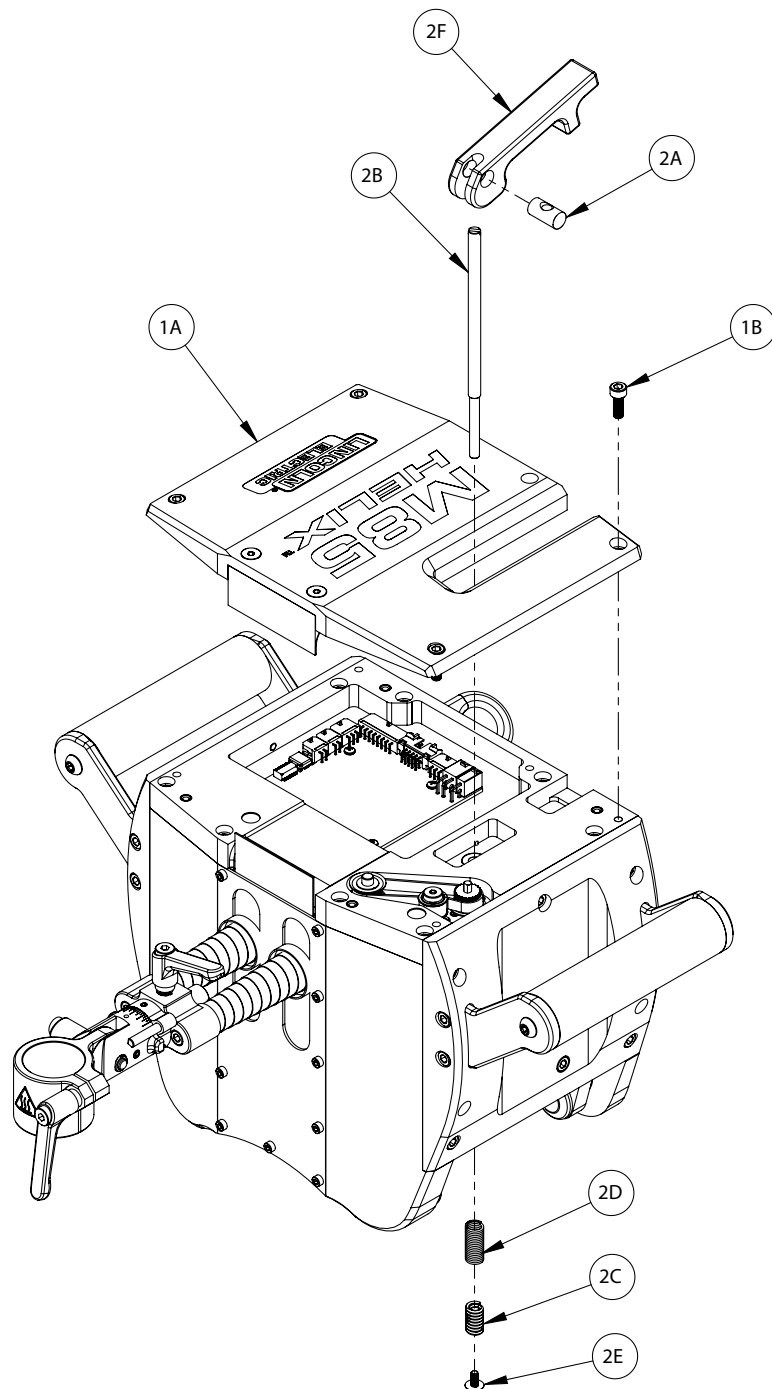

9-30-18

NOTE: This Parts Manual is provided as an informative guide only. When ordering parts, always refer to the Lincoln Electric Parts List.

Indicates a change in this printing.

Use only the parts marked "x" in the column under the heading number called for in the model index page.

ITEM	DESCRIPTION	PART NO.	QTY.	1	2	3	4	5	6	7	8	9
	M85 Weld Head Top Panel											
1	M85 Top Cover Kit		1	x								
1A	Top Cover (NFS)	9SM24540	1	x								
1B	Screw (NFS)		5	x								
2	Clutch Lever Assy	9SS30726-2	1	x								
2A	Cam Nut (NFS)		1	x								
2B	Shaft (NFS)		1	x								
2C	300 lb Spring (NFS)		1	x								
2D	5 lb Spring (NFS)		1	x								
2E	Screw (NFS)		1	x								
2F	Clutch Lever	9SS29699	1	x								

NOTE: This Parts Manual is provided as an informative guide only. When ordering parts always refer to the Lincoln Electric Parts List.

P-788
Weld Head Internal Assembly

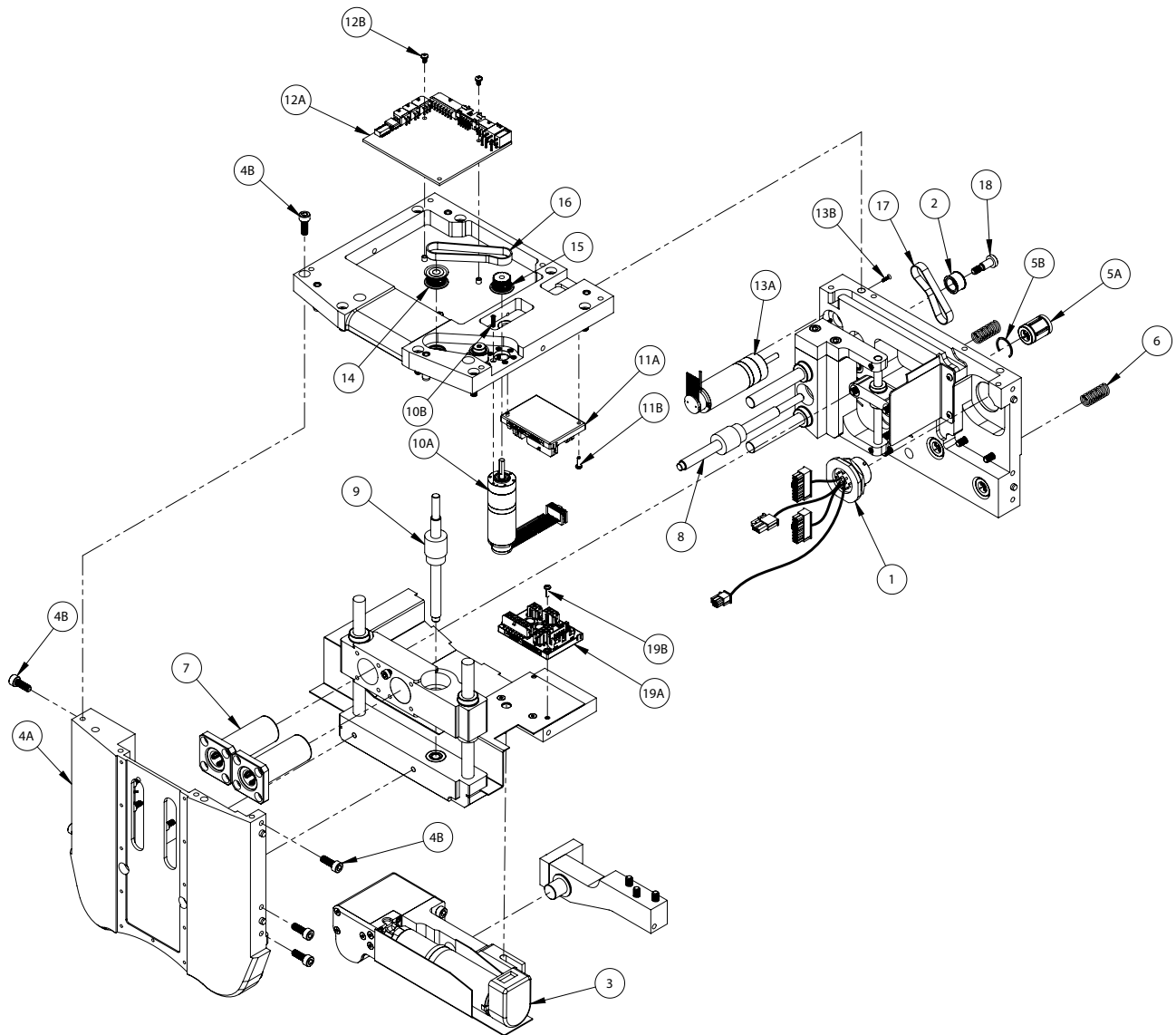

9-30-18

NOTE: This Parts Manual is provided as an informative guide only. When ordering parts, always refer to the Lincoln Electric Parts List.

P-788
Weld Head Internal Assembly

Indicates a change in this printing.

Use only the parts marked "x" in the column under the heading number called for in the model index page.

ITEM	DESCRIPTION	PART NO.	QTY.	1	2	3	4	5	6	7	8	9
	M85 Weld Head Internal											
1	Tractor Input Harness	9SM23043	1	x	x							
2	Idler	9SM24541	1	x	x							
3	Transmission	9SM24550	1	x	•							
3	Transmission	9SM23560	1	•	x							
4	Inboard Side Plate Assy	9SM24588	1	x	x							
4A	Inboard Side Plate (NFS)		1	x	x							
4B	Socket Head Cap Screw (NFS)		10	x	x							
5	3/8 Linear Bearing Kit	9SS28985	4	x	x							
5A	3/8 Linear Bearing (NFS)		4	x	x							
5B	Retaining Clip (NFS)		4	x	x							
6	Compression Spring	9SS29045	2	x	x							
7	1/2 Flanged Linear Bearing	9SS29988	2	x	x							
8	Oscillator Ball Screw Assy	9SS29990	1	x	x							
9	Torch Height Screw	9SS29991	1	x	x							
10	Torch Height Motor Assy	9SS30308-1	1	x	x							
10A	Torch Height Motor		1	x	x							
10B	Screws (NFS) (Not Pictured)		3	x	x							
11	Torch Height Controller Assy	9SM23204-2	1	x	x							
11A	Torch Height Controller (NFS)		1	x	x							
11B	Screws (NFS)		3	x	x							
12	Travel Controller Assy	9SM23203-1	1	x	•							
12	Travel Controller Assy	9SM23203-2	1	•	x							
12A	Travel Controller (NFS)		1	x	x							
12B	Screw (NFS)		3	x	x							
13	Oscillator Motor Assembly	9SS30496-1	1	x	x							
13A	Oscillator Motor (NFS)		1	x	x							
13B	Screw (NFS)		6	x	x							
14	6mm Pulley Assembly	9SS30524	1	x	x							
15	4mm Pulley Assembly	9SS30525	1	x	x							
16	Torch Height Belt	KP52136-1	1	x	x							
17	Oscillator Belt	KP52137-1	1	x	x							
18	Low Profile Shoulder Screw	9SS30505	1	x	x							
19	Oscillation Controller Assembly	9SM23204-1	1	x	x							
19A	Oscillation Controller (NFS)		1	x	x							
19B	Screw (NFS)		3	x	x							

NOTE: This Parts Manual is provided as an informative guide only. When ordering parts always refer to the Lincoln Electric Parts List.

P-788
Mechanized Torch

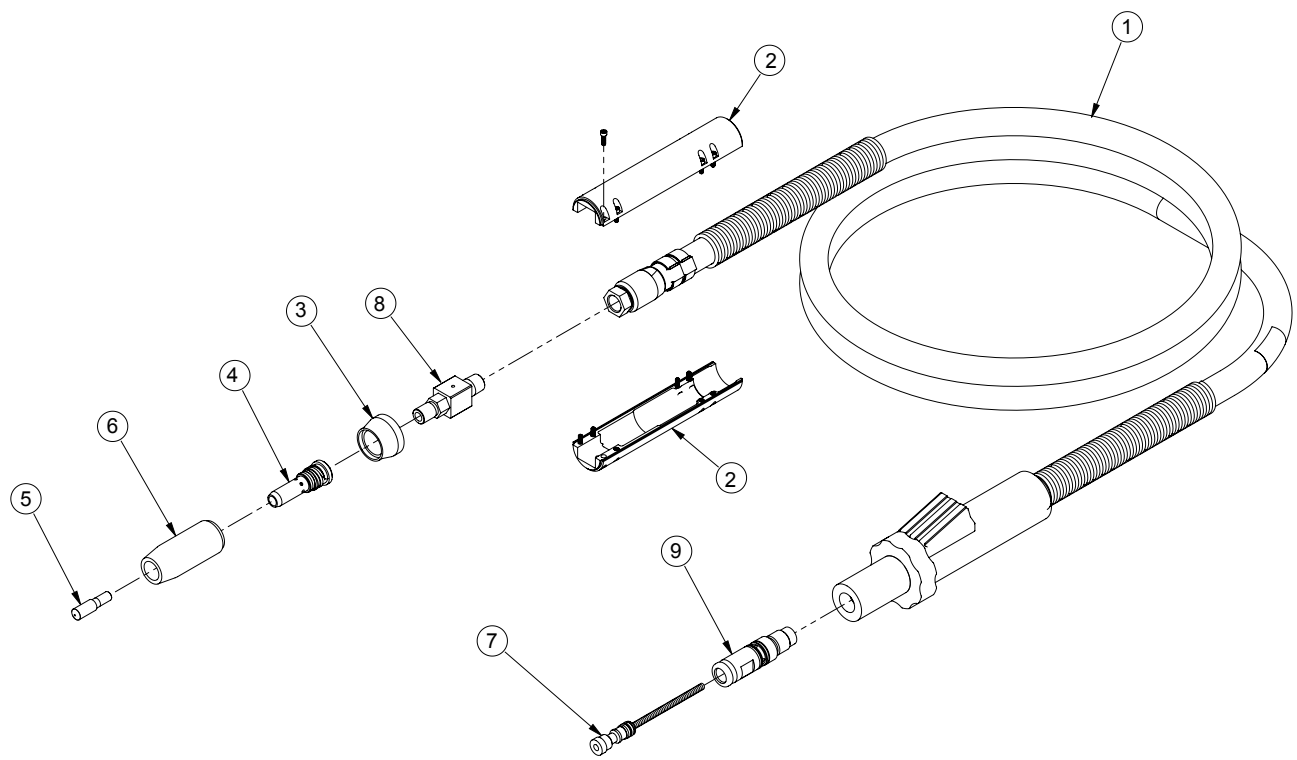

9-30-18

NOTE: This Parts Manual is provided as an informative guide only. When ordering parts, always refer to the Lincoln Electric Parts List.

Indicates a change in this printing.

Use only the parts marked "x" in the column under the heading number called for in the model index page.

ITEM	DESCRIPTION	PART NO.	QTY.	1	2	3	4	5	6	7	8	9
	Mechanized Torch											
1	Magnum Pro Torch Assembly 550A 25' 550A 15'	K52106-25 K52106-15	1	x x								
2	Torch Body Half	9SM23331-055	2	x								
3	Nozzle Bushing	KP52144-1	1	x								
4	Gas Diffuser	KP2747-1	1	x								
5	Magnum Pro Contact Tip Contact Tip 0.035" (0.9mm) Contact Tip 0.040" (0.9mm) Contact Tip 0.045" (0.9mm) Contact Tip 0.052" (0.9mm) Contact Tip 1/16" (0.9mm)	KP2745-035R KP2745-040R KP2745-045R KP2745-052R KP2745-116R	1	x x x x x								
6	Magnum Gas Nozzle Nozzle 1/8" (3.2mm) Recessed Nozzle Flush Nozzle 1/8" (3.2mm) Stick Out	KP2743-1-62R KP2743-1-62F KP2743-1-62S	1	x x x								
7	Magnum Pro 550 Wire Liner Wire Liner 0.030 - 0.045" (xx= 15' or 25' length) Wire Liner 0.052 - 1/16" (xx= 15' or 25' length)	KP45-3545-xx KP45-116-xx	1	x x								
8	Torch Coupler	9SS31385	1	x								
9	Connector Kit	K613-7	1	x								

NOTE: This Parts Manual is provided as an informative guide only. When ordering parts always refer to the Lincoln Electric Parts List.

P-788
Track Options

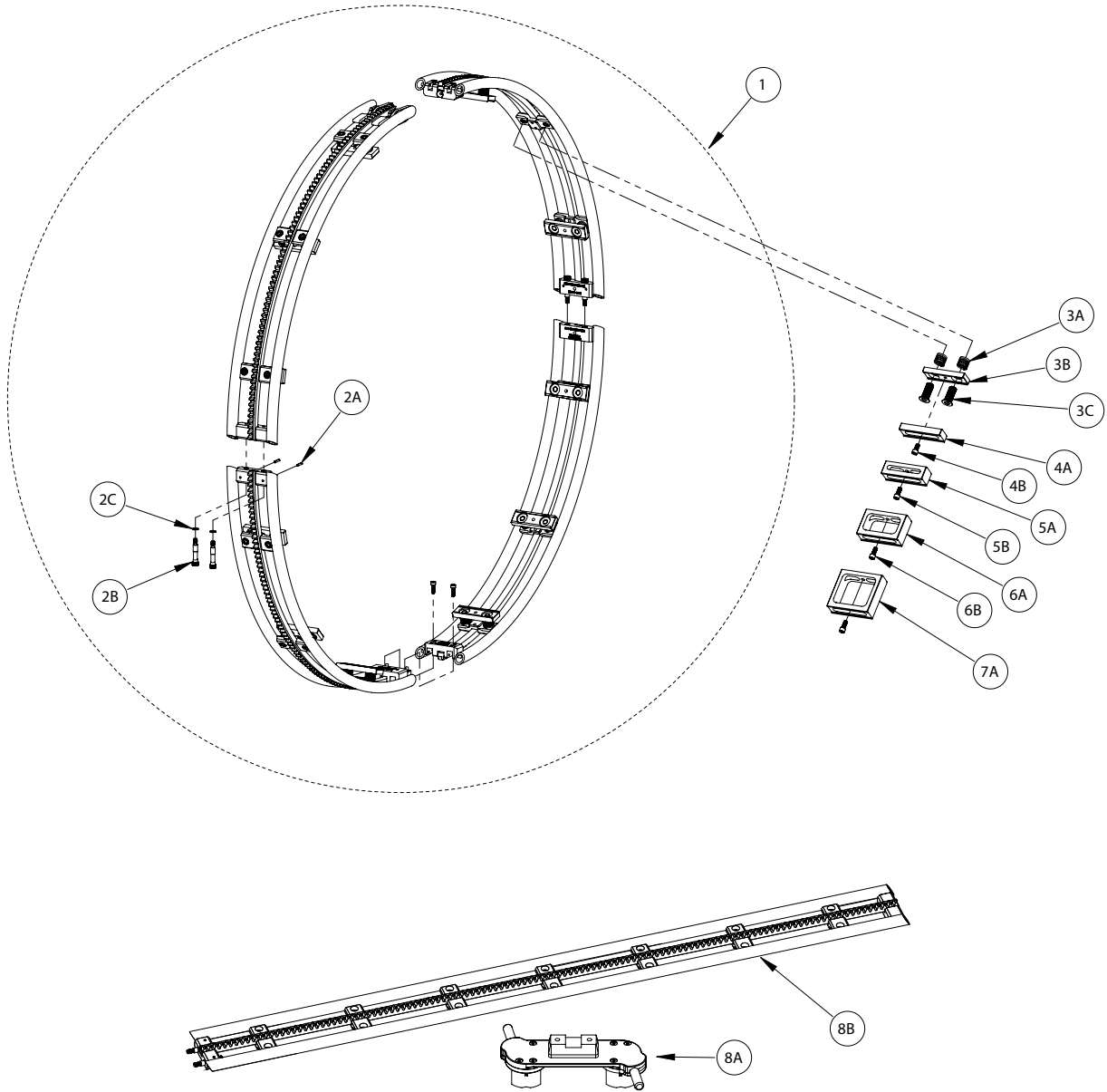

9-30-18

NOTE: This Parts Manual is provided as an informative guide only. When ordering parts, always refer to the Lincoln Electric Parts List.

Indicates a change in this printing.

Use only the parts marked "x" in the column under the heading number called for in the model index page.

ITEM	DESCRIPTION	PART NO.	QTY.	1	2	3	4	5	6	7	8	9
	Track Options											
1	Track Ring size -xx	K52000-xx	1	x								
	Track Ring 8"	K52000-08	1	x								
	Track Ring 10"	K52000-10	1	x								
	Track Ring 12"	K52000-12	1	x								
	Track Ring 14"	K52000-14	1	x								
	Track Ring 16"	K52000-16	1	x								
	Track Ring 18"	K52000-18	1	x								
	Track Ring 20"	K52000-20	1	x								
	Track Ring 22"	K52000-22	1	x								
	Track Ring 24"	K52000-24	1	x								
	Track Ring 28"	K52000-28	1	x								
	Track Ring 32"	K52000-32	1	x								
	Track Ring 36"	K52000-36	1	x								
	Track Ring 40"	K52000-40	1	x								
	Track Ring 44"	K52000-44	1	x								
	Track Ring 48"	K52000-48	1	x								
	Track Ring 52"	K52000-52	1	x								
	Track Ring 56"	K52000-56	1	x								
	Track Ring 60"	K52000-60	1	x								
Track Ring 64"	K52000-64	1	x									
2	Shoulder Bolt Kit		2	x								
2A	Roll Pin (NFS)	9SS29561-18	4	x								
2B	Bolt (NFS)		4	x								
2C	Shim (NFS)		4	x								
3	Track Shoe Kit	9SS30727	1	x								
3A	Track Shoe	9SS30520	1	x								
3B	Shoe Spring	9SS30534	2	x								
3C	Shoe Set Screw	9SS30526	2	x								
4	Shoe Extension 0.5" Kit		1	x								
4A	0.5" Shoe Extension (NFS)	K52060-05	1	x								
4B	Socket Head Cap Screw (NFS)		1	x								
5	Shoe Extension 1.0" Kit		1	x								
5A	1" Shoe Extension (NFS)	K52060-10	1	x								
5B	Socket Head Cap Screw (NFS)		1	x								
6	Shoe Extension 2.0" Kit		1	x								
6A	2" Shoe Extension (NFS)	K52060-20	1	x								
6B	Socket Head Cap Screw (NFS)		1	x								
7	Shoe Extension 3.0" Kit		1	x								
7A	3" Shoe Extension (NFS)	K52060-30	1	x								
7B	Socket Head Cap Screw (NFS)		1	x								
8	48" Flat Track w/ 3 Mag Shoes	K52090-1	1	x								
8A	Magnetic Shoe	K52089-1	1	x								
8B	48" Flat Track	K52083-48	1	x								

NOTE: This Parts Manual is provided as an informative guide only. When ordering parts always refer to the Lincoln Electric Parts List.

CUSTOMER ASSISTANCE POLICY

The business of The Lincoln Electric Company is manufacturing and selling high quality welding equipment, consumables, and cutting equipment. Our challenge is to meet the needs of our customers and to exceed their expectations. On occasion, purchasers may ask Lincoln Electric for advice or information about their use of our products. We respond to our customers based on the best information in our possession at that time. Lincoln Electric is not in a position to warrant or guarantee such advice, and assumes no liability, with respect to such information or advice. We expressly disclaim any warranty of any kind, including any warranty of fitness for any customer's particular purpose, with respect to such information or advice. As a matter of practical consideration, we also cannot assume any responsibility for updating or correcting any such information or advice once it has been given, nor does the provision of information or advice create, expand or alter any warranty with respect to the sale of our products.

Lincoln Electric is a responsive manufacturer, but the selection and use of specific products sold by Lincoln Electric is solely within the control of, and remains the sole responsibility of the customer. Many variables beyond the control of Lincoln Electric affect the results obtained in applying these types of fabrication methods and service requirements.

Subject to Change – This information is accurate to the best of our knowledge at the time of printing. Please refer to www.lincolnelectric.com for any updated information.



THE LINCOLN ELECTRIC COMPANY

22801 St. Clair Avenue • Cleveland, OH • 44117-1199 • U.S.A.
Phone: +1.216.481.8100 • www.lincolnelectric.com