

FTW 10-38

Tube-to-tubesheet weldhead

Tube-inside diameter range 9,3 - 36,7 mm
(0.366 - 1.445 inch)

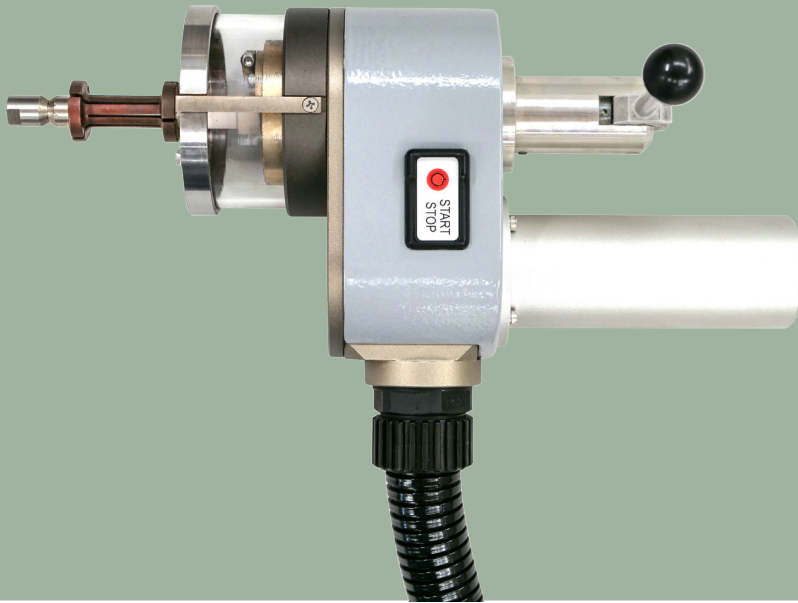

Features

- Compact, water-cooled weld head
- Tube-inside diameter range 9,3 - 36,7 mm (0.366 - 1.445 inch)
- Welding tubes flush, offset, protruding or behind the tubesheet
- Hose pack 6m (236.22 inch), water-cooled
- Electrode holder 0° in scope of delivery
- Transport case
- Compatible with FPA 4030 System controller

Accessories / Options

- Mandrels and spring sleeves
- Electrode holder
- Gas hood

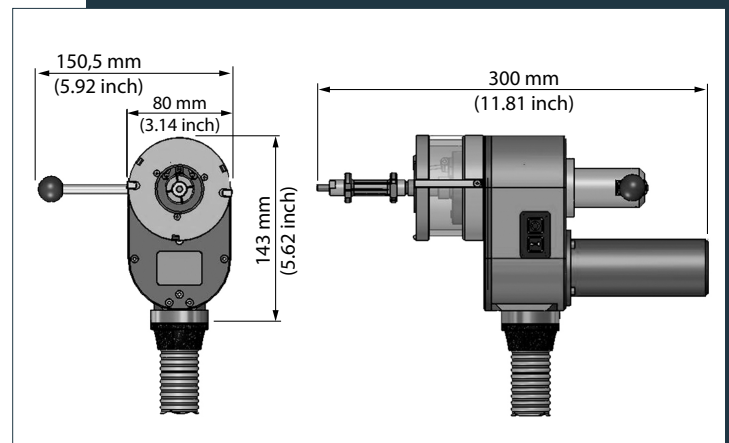

Technical data FTW 10-38

Tube inside-diameter range	ID 9,3 – 36,7 mm (0.366 - 1.445 inch)
Welding current max.	200 A
Rotation speed	max. 5 rpm
Weight	5 kg (11.02 lbs)