

FTW 10-60

Tube-to-tubesheet weldhead

Tube-inside diameter range 9,5 - 60,5 mm
(0.374 - 2.381 inch)

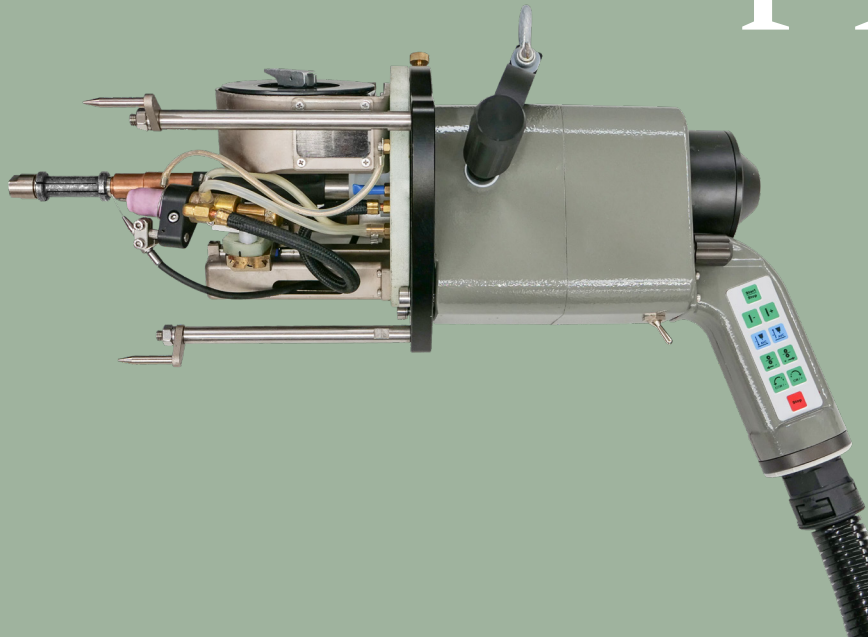

Features

- Robust, water-cooled weld head
- Tube-inside diameter range 9,5 - 60,5 mm (0.374-2.381 inch), optionally up to 120 mm (4.724 inch)
- Pneumatic centering
- Hose pack 8 m (314.96 inch), water-cooled
- Torch with electrode \varnothing 2,4 mm (0.09 inch)
- Transport case
- Compatible with FPA 4030 System controller

Accessories / Options

- Mandrels and spring sleeves
- Torch for electrode \varnothing 3.2 mm (0.12 inch)
- Extension-kit for inside \varnothing >60 mm (>2.36 inch)
- Titanium distribution nozzle-set
- Balancer

3 versions available:

- FTW 10-60 with pneum. centering
- FTW 10-60 with pneum. centering + Integrated wire feeder
- FTW 10-60 with pneum. centering + Integrated wire feeder + AVC

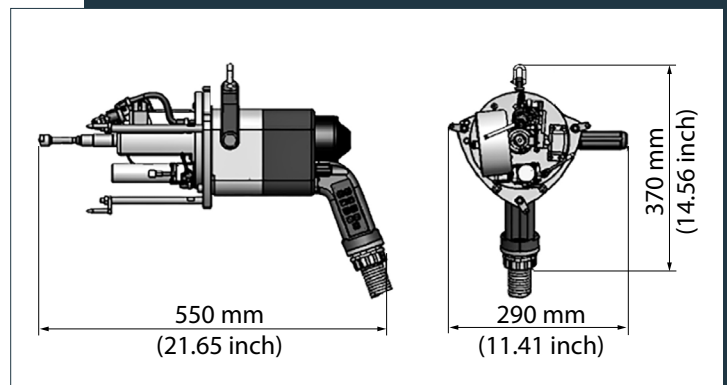

Technical data FTW 10-60

Tube inside-diameter range	9,5 – 60,5 mm (0.374-2.381 inch)
Welding current max.	200 A
Rotation speed	max. 5 rpm
Wire spool	1kg (2.2 lbs), D100
Wire diameter	0,8 - 1,5 mm (0.031 - 0.059 inch)
Weight without wire feeder	8 kg (17.63 lbs)
Weight with wire feeder	10,5 kg (23.14 lbs)
Weight with wire feeder & AVC	11 kg (24.25 lbs)